

Spintronics, Principles, Devices and Materials

1. Principles

R Srinivasan

Spintronics is creating new excitement in the scientific world. In Part 1 of this two-part article, we will deal in an elementary fashion with the principles of spintronics.

Introduction

Spintronics is the branch of science dealing with the active manipulation of spin degrees of freedom in solid state materials. The science has a long tradition starting with Mott's theoretical work in 1936 on spin-polarised transport. But interest in this field was dormant till the work of the groups of Albert Fert in Paris and Peter Grnberg in Julich. The field has seen an explosive growth since the discovery of Giant Magneto-Resistive (GMR) materials, and has found very successful commercial applications. In this two part article an elementary presentation of the subject is given.

Electrons in Normal and Ferromagnetic Metals

Electrons in metals are free. They occupy a partially filled conduction band. If we take a normal metal (or a metal in the paramagnetic state) the energy of the electron is independent of the orientation of its spin. Choosing a direction of quantisation, an electron with spin angular momentum projection $(1/2)(h/2\pi)$ along this direction has the same energy as an electron with spin projection $-(1/2)(h/2\pi)$. If we plot the density of states in the conduction band of such a metal we get a diagram as shown in *Figure 1*.

At the absolute zero of temperature, the Fermi level at energy ε_F represents the highest occupied energy state



R Srinivasan was the former director of Centre for Advanced Technology, Indore and at present a visiting Professr with the Laser-cooling Group, Raman Research Institute.

Keywords

Spin-polarization, magnetoresistance, spin-injection, spin-relaxation.



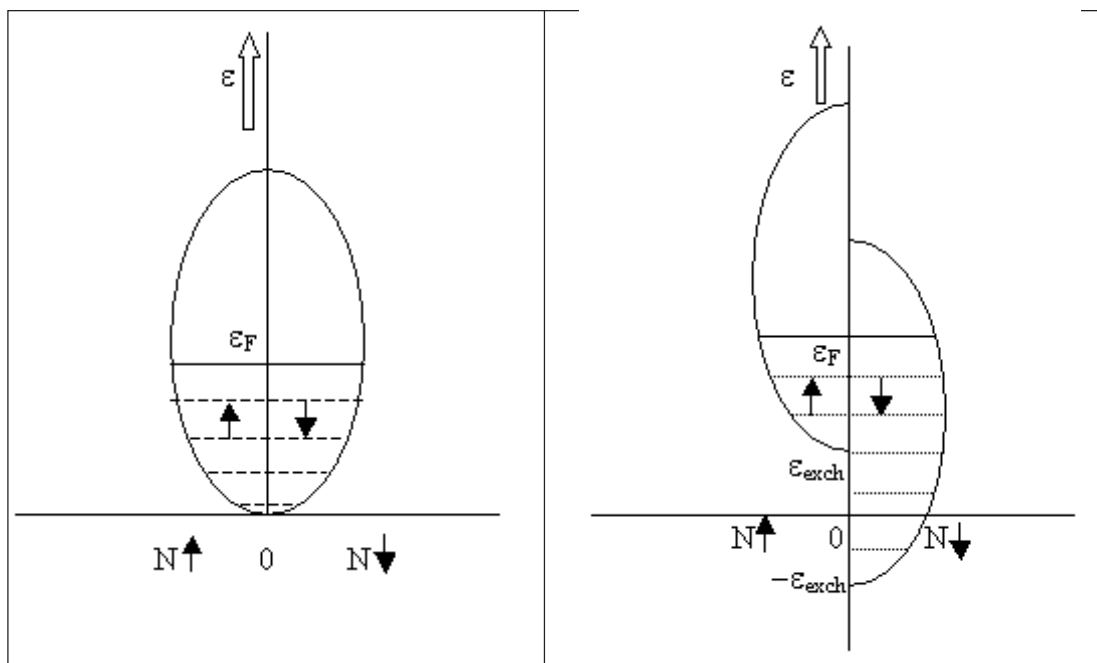

Figure 1 (left). Variation of the number density $N\uparrow$ of spin up and $N\downarrow$ of spin down states with energy ϵ in the conduction band in a normal metal. ϵ_F is the Fermi energy. Regions showed by dashed lines up to ϵ_F represent filled states.

Figure 2 (right). Variation of number density of states $N\uparrow$ of up-spin and $N\downarrow$ of down-spin as a function of energy ϵ in a ferromagnetic metal. ϵ_F is the Fermi level. The exchange interaction between the electrons pushes down the energy of the down (\downarrow) spin electrons and pushes up the energy of the up (\uparrow) spin electrons.

in the conduction band. There are equal numbers of up-spin and down-spin electrons as shown by the equal area of the shaded regions in *Figure 1*. The total spin of all the electrons is therefore zero. Each electron carries a magnetic moment μ_B , which is pointing in a direction opposite to the spin projection. So the net magnetic moment of the material is zero.

If the metal is in the ferromagnetic state, the exchange interaction between the electrons lowers the down-spin energy relative to the up-spin energy. The number density of states gets modified as shown in *Figure 2*.

There are more down-spin electrons than up-spin electrons. We now say that the material is polarized and define the polarization P_n in terms of the number density $n\uparrow$ and $n\downarrow$ of the conduction electrons in the metal as

$$P_n = \frac{(n\uparrow - n\downarrow)}{(n\uparrow + n\downarrow)}. \tag{1}$$



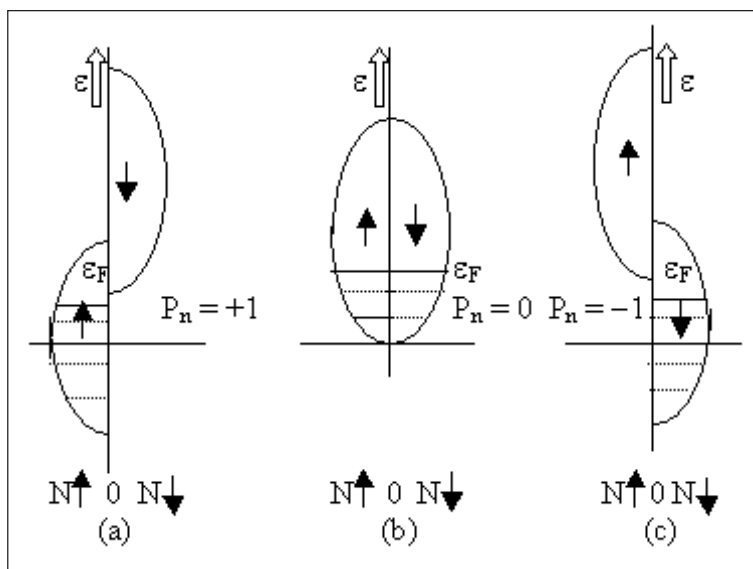

Figure 3. In diagram (a) no energy level for down-spin is occupied as the levels are above the Fermi level; in (b) both up-spin and down-spin levels are occupied by equal number of electrons; in (c) no up-spin level is occupied since all up-spin levels are above the Fermi level.

For a normal metal, which is paramagnetic, $P_n = 0$. P_n can have a maximum value of +1 when $n \downarrow = 0$ and a minimum value of -1 when $n \uparrow$ is zero. The corresponding number density of states curves are shown in *Figures 3(a,b,c)*. When $P_n = \pm 1$ we say the polarization is complete.

When P_n is non-zero but does not have the value +1 or -1, the polarization is partial. The polarization is accompanied by a spontaneous magnetization.

Injection of Spin Polarization

Creation of non-equilibrium spin polarization in an unpolarized material can be done in many ways. The simplest way is to apply a transient magnetic field to a paramagnetic metal. Since the paramagnetic susceptibility of a metal is small, it requires a very high magnetic field to create sizeable spin polarization.

Another method is to inject electrons from a ferromagnetic metal into a normal metal by applying an electric field. Let us consider the simple case where the ferromagnetic metal has a polarization +1. Electrical current

Injection is the creation of non-equilibrium polarisation in a metal or a superconductor or a semiconductor. Injection can be done by passing a current or by shining circularly polarised light.



Figure 4. Spin injection by a current passing from a ferromagnet to a normal metal.

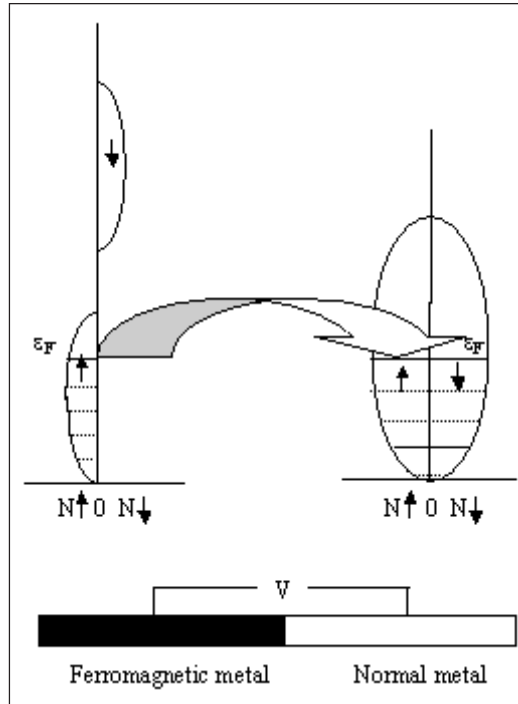

is carried only by electrons near the Fermi level and is proportional to the number density of states at the Fermi level. When an electric field is applied only electrons with spin up from the ferromagnetic half metal cross the junction and enter the normal metal creating a non-zero plus polarization in the metal. This is shown in *Figure 4*. This excess non-equilibrium polarization in the normal metal will be associated with a non-equilibrium magnetization. The spin polarization will relax to its equilibrium zero value in the metal exponentially with a relaxation time τ_s . The spin relaxation time is of the order of nanoseconds and is much larger than the momentum relaxation time. Spin relaxation occurs because of spin-orbit coupling, which produces a spin-dependent potential.

The injected polarisation will relax to its equilibrium value with a characteristic relaxation time τ_s .

The resultant momentum scattering becomes spin-dependent. If we cut off the current flow, the excess polarization (and hence magnetization) will decay. If we



maintain the current, a steady non-equilibrium polarization will be built up in the metal when the rate of generation of polarization balances the rate of decay. This non-equilibrium polarization will decay as one moves away from the junction into the interior of the normal metal. The characteristic length L over which the decay occurs is called the spin diffusion length. Polarization injection from a ferromagnetic metal into a superconductor can also be carried out with reasonable efficiency by current injection.

Injected polarization will depend on the magnitudes of the (i) resistance per unit area of the contact (r_c), (ii) the resistance per unit area of the ferromagnetic metal (r_F) and (iii) the resistance per unit area of the normal metal (r_N). Even if $r_s = 0$ (i.e. the contact is perfect) the injected polarization decreases as the resistance mismatch between r_F and r_N increases.

Creating a substantial polarization by current injection from the ferromagnetic metal to a semiconductor is more difficult. Even assuming an ohmic contact between a ferromagnetic metal and the semiconductor, injection of spin polarization is severely limited by the resistance mismatch between the ferromagnetic metal and semiconductor. Using a magnetic semiconductor as a spin injector one can reduce this resistivity mismatch and obtain substantial spin injection.

There is an optical method of spin injection in a direct band gap semiconductor like GaAs. This depends on optical pumping using circularly polarised light. The mechanism is too complicated for discussion here. In a p-type semiconductor, in which the majority carriers are holes, the electron spin polarization will decay not only by spin relaxation but also by recombination of the electrons with holes. In such materials the steady state spin polarization P_n of the injected electrons is smaller than the instantaneous polarization P_{n0} created

Injected polarization will be small if the resistance mismatch between the two materials is large.

Optical spin injection in a III-V semiconductor is possible. The behaviour of non-equilibrium polarization is different for a p-type and n-type semiconductor.



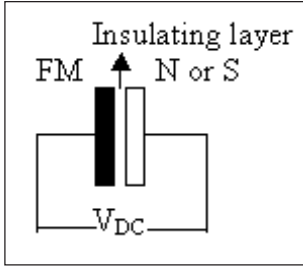

Figure 5. Tunnel Junction with a FM and a metal (N) or a superconductor (S).

by optical pumping.

$$P_n = \frac{P_{n0}}{(1 + \tau_r/\tau_s)}, \quad (2)$$

where τ_r is the lifetime of the electron for recombination with a hole and τ_s is the relaxation time for spins. τ_s is of the order of nanoseconds varying from picoseconds to microseconds. Since τ_r is less than τ_s in p-type semiconductors the steady state polarization is only slightly less than P_{n0} , which has a value of 1/2 for GaAs. Also the steady state polarization is independent of the intensity of the light.

If the spin polarization is created optically in a n-doped direct band gap semiconductor like GaAs, in which the holes are minority carriers, the lifetime for recombination of the injected electron with a hole is very long and plays no role in determining P_n . The value of the steady state polarization will vary as

$$P_n = \frac{P_{n0}}{[1 + (n_0 r_G) t_s]}, \quad (3)$$

where n_0 is the majority carrier concentration in the n-type semiconductor and r_G is the rate of generation of spin polarization by photo-excitation. r_G is proportional to the intensity of the light.

One can also use a tunnel junction to inject polarization. Such a junction is shown in *Figure 5*. On one side is a ferromagnetic metal in a thin film form. On the other side is a thin film of a normal metal or a superconductor. In between is a thin oxide layer.

When a DC voltage is applied across the junction electrons can tunnel through the barrier from the ferromagnetic metal to the normal metal or vice-versa depending on the direction of the applied voltage. In this way excess polarization can be created in the normal metal (or superconductor). It is assumed that the oxide layer

Polarization can be injected by electron tunnelling through an insulating barrier in a tunnel junction between a ferromagnetic and normal metal.



does not contain any magnetic materials to cause spin-flip scattering. One can use a ferromagnetic semiconductor on one side and a normal semiconductor on the other side to create non-equilibrium polarization in a non-magnetic semiconductor.

If the polarisation in the ferromagnet is partial, then the current will be carried both by up and down spins. The contribution to the current \mathbf{j} will be different for the two spins due to the different number densities for the two spin states at the Fermi level in the ferromagnetic metal. One can define the polarization of the current P_j by

$$P_j = \frac{(j \uparrow - j \downarrow)}{(j \uparrow + j \downarrow)}. \quad (4)$$

In a tunnel junction one may use the conductance $G \uparrow$ and $G \downarrow$, for up and down spins respectively, to define a polarization

$$P_G = \frac{(G \uparrow - G \downarrow)}{(G \uparrow + G \downarrow)}. \quad (5)$$

It should be remembered that the value of polarization measured using different quantities like j and G need not be the same.

Detection of Spin Polarisation

How do we detect the non-equilibrium spin polarisation created? We shall describe a simple method shown here in *Figure 6*.

Spin polarization is injected into the normal metal from the ferromagnetic metal FM1 on the left by current injection. This produces excess electrons with spin up in the normal metal. We have a second FM metal in contact with the normal metal. Its magnetization is parallel to the magnetization of the spin injector ferromagnet. By connecting a voltmeter M between the normal metal NM and the spin detector FM2, one can measure an

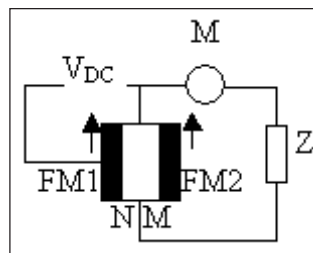
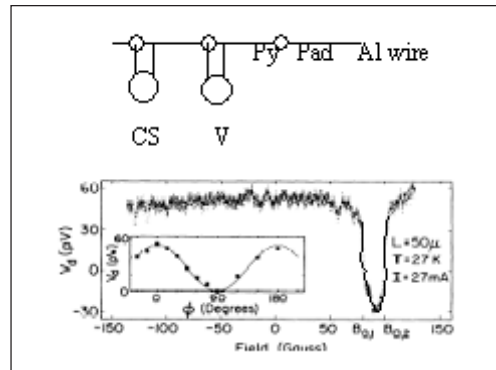

Figure 6. A normal metal is sandwiched between two ferromagnetic metals. A non-equilibrium polarization is induced into NM from FM1 on the left. One will measure a voltage or current on the meter M between NM and FM2 on the right.

Induced polarization can be detected by having a second soft ferromagnetic metal in contact with the normal metal. When a non-equilibrium polarization is induced from the ferromagnetic metal FM1 into the normal metal, a voltage or current is seen in the meter M. The reading on meter M will change when the magnetization in FM2 is reversed.



Figure 7. Johnson and Silsbee's [1] arrangement for measuring spin injection.



emf. Or by connecting a low impedance Z between NM and FM2 one can measure a current. The value of the voltage (or current) measured in the secondary circuit will depend on the orientation of the magnetization in the spin injector. For example one will measure a large current when the two spin orientations are parallel and a small current when they are antiparallel. This difference in current can be used to quantify the injected polarization and measure its decay time.

Johnson and Silsbee [1] first demonstrated spin injection in 1985 from a ferromagnetic metal into pure aluminium at 4 K. Their arrangement was the following. On an aluminium wire permalloy (Py) pads were deposited. Permalloy has a high permeability. The spacing between the pads was 50 microns. When an inhomogeneous magnetic field was applied parallel to the wire (see *Figure 7*) the magnetization in permalloy pads get aligned in the direction of the field. By connecting a voltage source between the permalloy pad at $x = 0$ and the adjacent aluminium wire, polarization was induced in the aluminium wire. By measuring the spin induced voltage V_d between a permalloy pad at $x > 0$ and the aluminium wire, one can measure the spin polarization and how it decays with distance. First the magnetic field was made negative so that both permalloy pads at $x = 0$ and $x = x_1$ had the same orientation of magnetization. V_d had a certain value. Then the magnetic field

Johnson and Silsbee demonstrated spin injection from a Py pad to Aluminium at 4 K using the arrangement in *Figure 7*.



was swept from negative to positive values. At a positive field B_{01} at $x = 0$ the magnetisation of the permalloy pad at $x = 0$ was reversed while that at $x = x_1$ was unreversed. At this point the voltage measured changed sign. At a higher value B_{02} of the magnetic field at $x = 0$, the magnetization of the second pad was also reversed. The magnetization of both the pads was now parallel and the voltage went back to its original value as shown in *Figure 7*.

Johnson *et al.* [2] later described a three terminal device to measure spin injection at room temperature from FM to normal metal and reported data which require nearly 100% spin polarisation to interpret them. These results have been criticised. It is difficult to detect spin injection unambiguously using this technique at room temperature. Disturbing effects arise from other spin related phenomena such as spin dependent interface scattering, anisotropic magneto-resistance and Hall effects.

Jedema, Filip and van Wees [3] used what they called as a non-local arrangement to measure spin injection. They deposited two Py films each 40 nm thick on a thermally oxidized substrate. These strips had different lengths and widths so that the coercive fields of the two Py films were different. On these permalloy pads a copper cross was deposited by e-gun evaporation at 10⁻⁸ mbar pressure. Prior to deposition the oxide layer on the Py films were removed by ion milling to ensure transparent contacts. This is shown in *Figure 8*.

When the magnetic field was ramped up the two Py pads first get oppositely magnetized due to the difference in their coercive fields and then the voltage measured on the voltmeter rises to a high value indicating a high resistance. As the field is increased further the two permalloy pads get magnetized in the same direction and the resistance falls.

Jedema *et al.* developed a non-local arrangement for measuring spin polarisation even at room temperature (*Figure 8*).



Figure 8. Arrangement of Jedema et al [3] to measure spin injection at room temperature. Continuous lines represent change in resistance during an upward ramp of the magnetic field and dashed lines during a downward ramp.

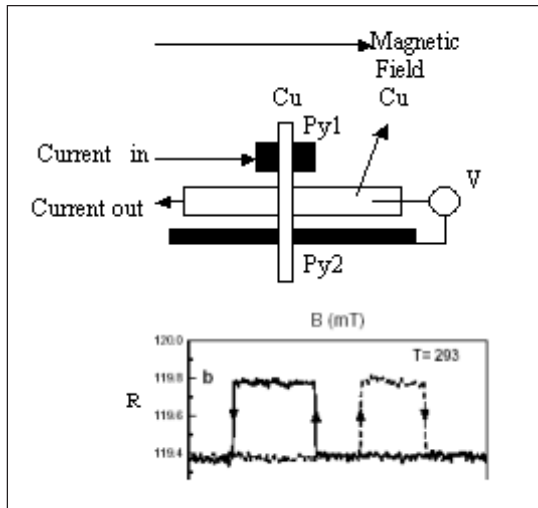

Suggested Reading

- [1] M Johnson and R H Silsbee, *Phys. Rev. Lett.*, Vol.55, p.1790, 1985.
- [2] M Johnson, *Phys. Rev. Lett.*, Vol. 70, p.2142, 1993.
- [3] F J Jedema, A T Filip, and B J van Wees, *Nature*, Vol. 410, p.345, 2001.
- [4] M Johnson, Spin injection: A survey and review, *J. of Superconductivity: Incorporating novel magnetism*, Vol.14, p.273, 2001.
- [5] Igor Zutic, Jaroslav Fabian and S Das Sharma, *Spintronics: Fundamentals and Applications*, *Reviews of Modern Physics*, Vol.76, p.323, 2004.

Address for Correspondence
 R Srinivasan
 Raman Research Institute
 C.V.Raman Avenue
 Sadashivanagar
 Bangalore 560 080, India.
 Email: rsv@rri.res.in

In the case of polarization injection by optical methods one can use the intensity of luminiscence I^+ , with circular polarisation σ^+ and I^- with circular polarization σ^- to define a polarization of spin injection

$$P_{\text{opt}} = \frac{(I^+ - I^-)}{(I^+ + I^-)}. \quad (6)$$

Conclusion

In this part we have defined spin polarization in a ferromagnetic metal and discussed methods of spin injection either by using a resistive contact between the ferromagnetic metal and a normal metal, a semiconductor or a superconductor, or by using a tunnel junction with an insulating layer between a ferromagnetic metal and a normal (or superconducting) metal. In a direct band gap semiconductor spin can also be injected by optical pumping using circularly polarized light. Methods for detecting non-equilibrium spin polarization are described.

In the next part the principles of some proposed devices will be discussed and the materials likely to be used in such devices will be presented.