

Propulsion of the Putt-Putt Boat – 2

V Sharadha



V Sharadha is a III year mechanical engineering student at Indian Institute of Technology, Chennai. This work was done when she was JNCASR summer fellow in 2003 at IISc.

¹ Part 1. *Resonance*, Vol.9, No.6, pp.66-73, 2004.

In the previous part ¹, we saw that the boat is made up of a small shallow chamber, covered by a thin copper diaphragm connected to the water astern of the boat by two pipes, that need to be initially primed. As the base of the chamber is heated, the diaphragm vibrates and the boat putt-putts its way through the water as long as the flame glows.

An analysis of the hydrodynamic forces involved in the working of the putt-putt boat was presented earlier. As a continuation, this part will deal with the thermodynamics of the toy's working.

An experiment done by Finnie and Curl [1] using a glass model, revealed the mechanism. Steam was found to be generated in the chamber as soon as water came in contact with the hot metal surface. The water boils almost instantaneously and the pressure of steam drives out some of the water in the pipes. Meanwhile, the steam in the cooler pipes condenses and the pressure drop in the chamber draws in water from the surroundings, ready for the next cycle to start.

Thermodynamics

Since the diaphragm does not seem to affect the boat's operation, we replaced it with a glass plate to observe the functioning of the boat within the chamber. High speed recording indicate that the chamber is mostly devoid of water during operation and at one or two locations closest to the flame, we saw a drop condensing and turning to steam, which seems to drive the boat. The principle is similar to flash boiling. However, we measured pressure and volume changes for a boat with a normal diaphragm.

Keywords

Putt-Putt boat, propulsion, thermodynamic analysis,



Measurements

Volume Measurements

We consider the thermodynamic system to be that *mass of water* which repeatedly undergoes boiling and condensation. The volume changes of this system will be directly reflected in the motion of the water in the pipes, water being incompressible.

To facilitate observation, a couple of glass pipes of length 15cm were connected to the existing metal pipes using a pair of 3cm long PVC tubes. This reduced the operational frequency of the boat to 6Hz. A small air bubble introduced into the glass pipe was used as a tracer. The volume changes taking place in the chamber are proportional to the displacement of the bubble. Images of the bubble motion were recorded on a high-speed CCD camera at 500 frames per second.

The recordings showed that the bubble was in simple harmonic motion. The actual volume of the system under consideration is the net value of the volume of the rigid chamber, the volume changes due to the motion of the water column in the pipes and the volume changes due to the oscillatory motion of the diaphragm. The volume changes due to the diaphragm motion could not be accounted for quantitatively.

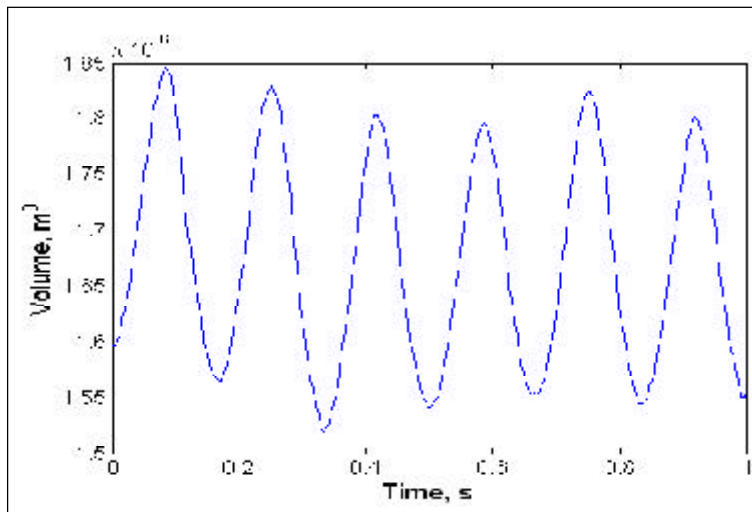

Figure 1. Plot of volume vs. time



Velocity

As mentioned earlier, the displacement of the bubble in the glass tube was found to be simple harmonic, implying that the velocity of the water in the glass is also sinusoidal. This means that suction and exhaust take place at the same average speeds. From our fluid mechanical analysis (Part 1), it is known that, near the exit port of the pipes, the flow patterns produced during suction and ejection are different, thereby resulting in a net forward thrust. During the exhaust phase the flow is in the form of a jet, and it is in this phase that most of the thrust is produced.

Pressure

The displacement of the bubble in the boat tubes also gives the displacement of the fluid in the tube, and therefore the velocity and acceleration of the fluid in the tube are known. Thus the pressure at the pipe exit can be related to the pressure inside the chamber if the viscous effects are accounted for. Therefore if the pressure at the pipe exit were measured, we could calculate the pressure inside the boat chamber, which is the sum of the two pressures:

- i) pressure due to the simple harmonic motion of water and
- ii) the pressure at the exit port of the pipes.

Figure 2.

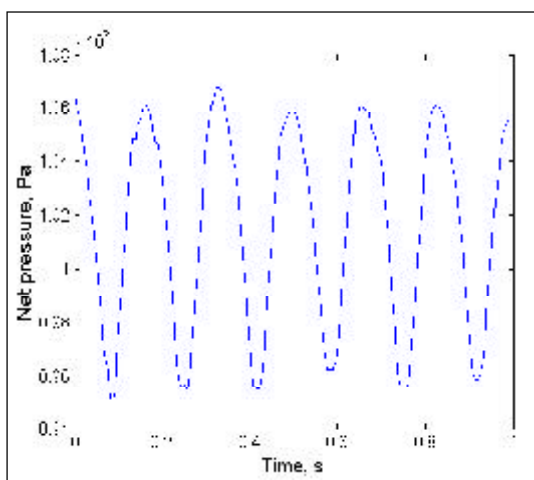

The former can be obtained from the measurements made of the bubble motion, as described above. The pressure at the exit was measured using a bent tube as a manometer taking into account the inertial component. This apparatus was placed, carefully aligned in the flow direction, 1cm downstream of the pipes. It was placed at a distance of 1cm from the jet exit which was a compromise between measuring the pressure at the exhaust and disturbing the flow as little as possible. *Figure 2* shows the pressure versus time, measured using this arrangement.



The manometer readings were recorded using the high speed camera mentioned previously. We measured the level in the manometer tube at high magnification to resolve the pressure adequately. To get the phase relationship in the pressure with the velocity in the tubes, we recorded simultaneously both the manometer level and the motion of the tracer bubble in the tube using a mirror.

Thrust Measurements

The thrust produced by this boat is smaller than the thrust produced in an unmodified boat. Hence, the low friction pulley system employed previously for thrust measurements could not be used here, as the errors due to friction would be quite significant. Instead, the set-up shown in *Figure 3* was used. A string is connected between the boat and a support above the water level. A small weight W hangs from a point in between on the string.

The thrust F can be approximated to Wa , without significant errors, if a is less than 5 degrees and T_2 is much smaller than T_1 . T_1 and T_2 are the tension forces in the string.

The thrust in this case was measured to be around 1.23mN. The drag calculated for a boat velocity of 11cm/s, using a drag coefficient (C_D) value of 0.045 and wetted area, comes to about 1.25mN, which agrees quite well with the measured thrust.

Figure 3. The set-up and force diagram for thrust measurement.

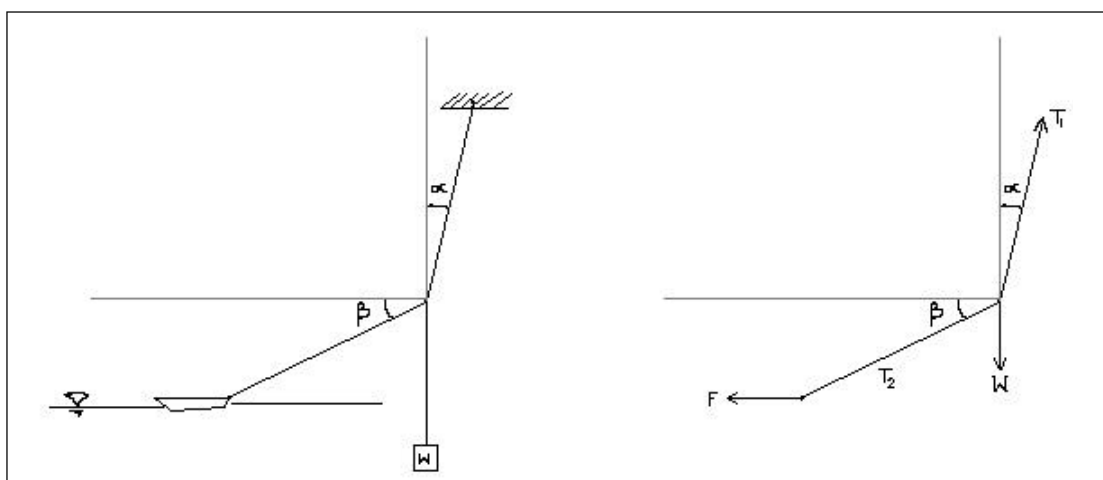

Suggested Reading

- [1] I Finnie and R L Curl, *Physics in a Toy Boat*, *American Journal of Physics*, Vol. 31, p. 289, 1962.
- [2] J S Miller, *Physics in a Toy Boat*, *American Journal of Physics*, Vol. 26, p.199, 1958.
- [3] R S Mackay, *Boat Driven by Thermal Oscillations*, *American Journal of Physics*, Vol.26, p.583, 1958.

Thermodynamic Analysis

Thermodynamic analysis provides insight into the actual process that powers the putt-putt boat. Every thermodynamic process can be characterized by a cycle that can be depicted using a pressure-volume (P-V) diagram. Pressure and volume can be measured separately and coupled appropriately to obtain the P-V diagram. The area of the P-V diagram is the work done by the medium (steam) per cycle. Since the work output can be calculated from the fluid mechanics part of the analysis, the propulsive efficiency can be computed from the P-V diagram. The pressure in the chamber was derived from the pressure measured near the exit using the unsteady Bernoulli equation. The volume variation with time was obtained from the measured bubble motion.

The P-V Diagram

The P-V diagram averaged over 5 cycles is shown in *Figure 4*. The averaging was done to obtain a smooth P-V curve.

The P-V plot so obtained loosely resembles the Lenoir cycle. The area within the closed P-V curve gives the work output.

Figure 4. P-V plot averaged over 5 cycles.

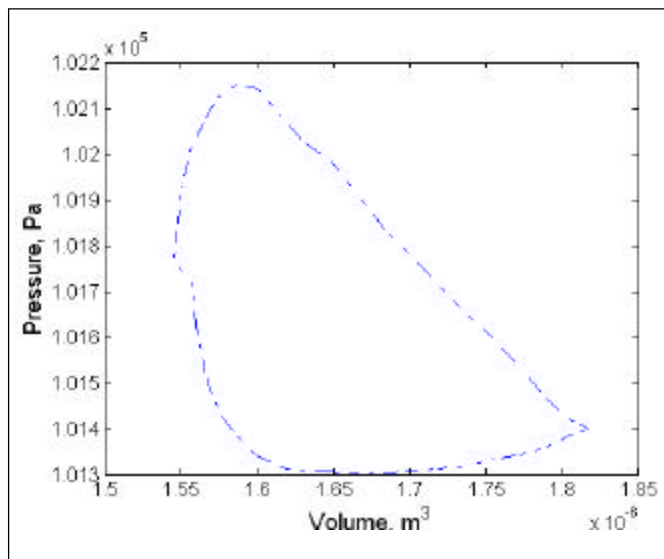

Calculations

Power output of the boat: The power output of the boat was calculated as the product of the thrust produced by the boat and its velocity measured under steady-state conditions. The power output so obtained is ~0.135mW.

Work output of the cycle: The area within the closed curve in the P-V diagram was calculated to be ~0.125 mJ. The power output of the cycle for a 6Hz operational frequency, comes to about 0.75mW.



Temperature Measurements

We attempted to measure the temperature in the chamber using a copper-constantan thermocouple inserted in the chamber, in conjunction with an Agilent 34970A data acquisition system. The sampling frequency was 10 milliseconds. The working temperatures changed between 98.5 °C and 95 °C. These values are to be treated as approximate. A smaller probe with better frequency response would be needed. The thermocouple data are not accurate enough to calculate the efficiency of the corresponding Lenoir cycle.

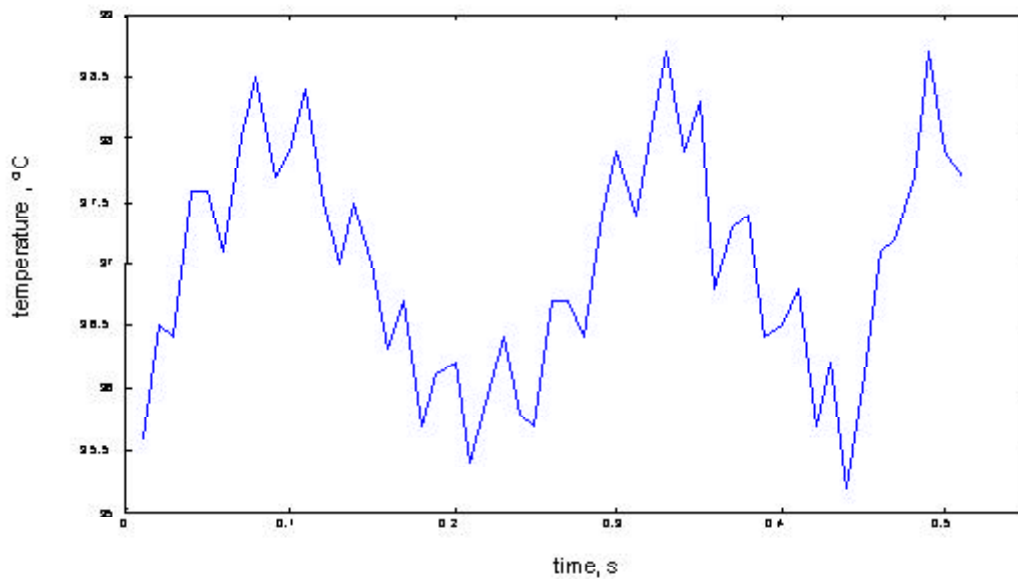

The average lamp has about 1 g of candle wax which burns for about 16 minutes. For a calorific value of 800 cal/g, this gives a power of 4W for the candle. Some of the heat from the candle is lost and not transferred to the chamber. And only a small part of the heat transferred to the chamber is converted to work output.

Efficiency: Defining the propulsive efficiency of the boat as the ratio of the power output of the boat to the power output of the cycle, we obtain an efficiency of 0.18 for the modified boat.

The overall efficiency of the boat is therefore $(0.135 \times 10^{-3})/4$, that is only about 3×10^{-5} . Therefore, this mode of propulsion is only suited for toys, where efficiency is not a major concern.

Address for Correspondence
V Sharadha
III Year
Mechanical Engineering
Student
Indian Institute of Technology
Chennai 600 036

