Self Assembled Monolayers

T Pradeep

In recent years, a number of systems have been shown to spontaneously assemble on appropriate solid surfaces to form films with thicknesses of molecular dimensions. The special techniques needed to prepare, characterise and study such monolayers are described. The potential applications of these systems as catalysts, sensors, electro-optic and other materials are summarized.

T Pradeep is at the
Department of Chemistry
and Regional
Sophisticated
Instrumentation Centre,
IIT, Chennai.

Introduction

Surface and interfacial phenomena have attracted scientists of diverse disciplines. Of the variety of processes occurring at surfaces, adsorption and concomitant catalytic transformations have been widely explored and constitute some of the most intensely pursued areas of contemporary research. Perhaps, the most important step in these chemical processes is adsorption of a molecular layer of the incoming reactant at the surface. Although the concept of monomolecular films is nearly two centuries old, the deliberate organisation of molecules on surfaces to form layers of molecular dimensions happened only in this century. Today, scientists are devising methodologies to assemble molecules of their choice on different surfaces for certain specific properties. This area is especially active, because of the fundamental issues as well as due to the potential applications. This article provides a bird's eye view of the fascinating area of monomolecular films.

History

It has been known from the time of sea voyages that when oil is spilled over water, the film formed dampens surface waves and ripples. The holiness of water has been attributed to this phenomena rather than to the oiliness of oil! Aristotle explained



Direct measurements of molecular dimensions became possible with the methodology introduced by Pockels, who worked mostly on her kitchen table.

it as due to the slipping of waves on an oil covered water surface, so that they do not make an impression. The first scientific studies of oil films on water were conducted by Benjamin Franklin (1706–1790), the American statesman scientist. He seems to have got interested in oil films during one of his frequent travels to Europe. An account of Franklin on oil films was published in *Philosophical Transactions of the Royal Society* in 1774, although his original interest in the subject dates back to 1757 during his travel to Europe. An interesting aspect of the account is that on careful reading, it implies the molecular nature of matter. Several scientists took up investigation of the subject in the 19th century, but the breakthrough occurred in 1890, with the publication of a series of papers by Rayleigh (1842–1919) on water surfaces. In one paper he discussed the effect of olive oil films on the surface tension of water and concluded that the films of olive oil are 10–20 Å in thickness. Rayleigh appeared to have the belief that oil spreads on the water surface to such an extent that the film thickness approaches molecular dimensions. Direct measurements of molecular sizes became possible with the methodology introduced by Pockels (1862–1935) and her 1891 letter to Rayleigh which was forwarded to the leading journal *Nature* for publication, describes the basic apparatus which constitutes the bare essentials of monolayer research even today. Pockels worked for about 18 years on the problem and mostly on the kitchen table, without any professional training. As she remarks to Rayleigh, “with regard to your curiosity about my personal status, I am indeed a lady”! Then came Langmuir (1881–1957), who developed theories of adsorption although his contributions spread into a number of areas. Langmuir developed a number of new techniques for studying films, the famous one being the film balance which bears his name. Blodgett (1898–1979) transferred the floating films on liquid surfaces (the Langmuir films) to solid surfaces (the Langmuir–Blodgett or L–B films). These films have interesting properties and serve as model systems to study a number of fundamental properties.



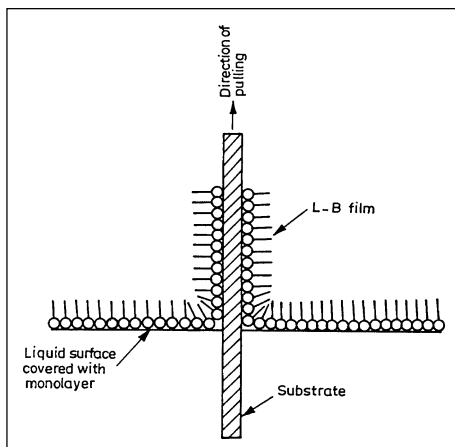

Figure 1. Schematic diagram of the preparation of a Langmuir–Blodgett film. When the substrate is removed from a liquid whose surface is contaminated with a layer of surfactant, a monolayer clings onto the surface. Upon application of a constant pressure on the film floating on the liquid surface and maintaining the rate of pulling a constant, it is possible to transfer a well-ordered film on to the surface of the substrate.

L–B Films

A monomolecular film assembled by the L–B methodology is easily visualised. If one lifts a glass plate through a barium stearate [$C_{17}H_{35}COO^-$] monolayer spread on water, the film which holds onto the plate will have the hydrocarbon tail pointing outward as shown in *Figure 1*. The surface after film preparation will be hydrophobic (water repelling). The film covered surface can be dipped back in the liquid depositing another layer of the film back-to-back and such a film will be hydrophilic (water liking). This kind of overlayer growth is called Y type growth. There are also other kinds of growth such as X and Z, in which similar surfaces are exposed all the time. Several tens of layers can be grown this way. The application of such films range from fundamental science to technology.

Self Assembled Monolayers (SAMs)

Self assembled monolayers are recent additions to the family of molecular films. These films are different from L–B films because they are self assembled to form an ordered molecular film, unlike L–B where they are transferred from the air-liquid interface to the surface. The SA monolayers are thus defined as molecular assemblies which form spontaneously by the immersion of a surface into a solution of surfactant. Thus depending on the surfactant and the substrate, monolayers vary.



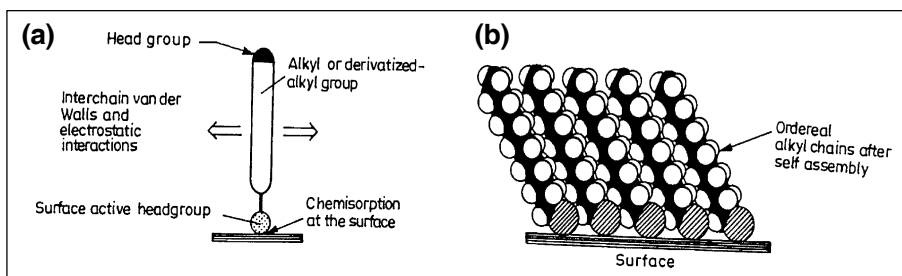

Figure 2. Schematic events during self assembled monolayer formation. (a) The surfactant having a head group which preferentially chemisorbs at the surface. Since the head group-surface interaction is strong, all the possible surface sites are occupied. The initial adsorption occurs quickly, within minutes. (b) Such a surface binding brings molecules closer so that inter-chain van der Waals interactions become important and the molecules stand up. This is a slow step in the monolayer formation, taking several hours.

The most common monolayers are formed with organosilicon derivatives, alkane thiols, dialkylsulphides, alcohols, amines and carboxylic acids on different surfaces. All molecules will not self organise on all substrates. The affinity between the molecule and the surface is an important factor. From a number of investigations, it is now clear that the first event in self organisation is the chemical bonding of the surface active group (the head group) to a surface site. It so happens that since the chemical formation reaction is highly exothermic, all the available surface sites are occupied. Since the kind of binding brings the molecules close to each other, the short range van der Waals forces become important. These interactions make the molecular chains attached to the head group stand up vertically, although with a tilt. An assembly of these molecules can extend over several hundreds of angstroms and an ordered oriented monomolecular layer results. The organised assembly can be schematically represented as in *Figure 2* with the corresponding events.

When one says *order* in an organised assembly, normally it implies only translational symmetry in a two dimensional surface. Close-packing in monolayers is related to the density of the film with reference to crystalline polyethylene. Monolayers are more ordered than liquids or amorphous solids. The terminal group has orientational disorder. It has been shown by studies that the orientations of terminal groups freeze only at fairly low temperatures of only a few Kelvins. It is also possible to exchange the molecules at the surface with molecules in solution. This could produce a monolayer of mixed molecules. This

implies that monolayer \leftrightarrow solution equilibrium is dynamic.

Variety of SAMs

There are several different kinds of SAMs. Carboxylic acids on aluminium oxide, silver and such other surfaces constitute one class. Long alkane chains terminating in a $-\text{COOH}$ group are the amphiphiles and upon the monolayer formation, the surfaces become hydrophobic. This is the most immediate change that one can observe (note that monolayers cannot be seen, since they are only of molecular dimensions). The other class of monolayers are alkylsilane derivatives, RSiX_3 , R_2SiX_2 or R_3SiX where X is chlorine or alkoxy and R is a long alkyl chain with or without a functionality. A surface bearing hydroxyl groups such as SiO_2 , SnO_2 or TiO_2 is exposed to a solution of these molecules for a few minutes. What occurs is that the surface hydroxyl groups react with $\text{Si}-\text{Cl}$ bonds and a chain of $\text{Si}-\text{O}-\text{Si}$ bonds forms at the surface leading to a compact monolayer as shown in *Figure 3*. The surface does not contain any chlorine at all. This monolayer can be further converted to form a multilayer as shown in *Figure 3*. The difference between this and the LB methodology is that the molecules are chemically bound to the surface and to each other. This makes the surfaces thermally and mechanically stable so that applications can be thought of.

Figure 3. (a) A monolayer of alkyltrichlorosilane on a hydroxylated surface. It is possible to make (b) a hydroxy terminated surface and then to make (c) a multilayer from such a surface. Adapted from A Ulman, *An Introduction to Ultrathin Organic Films: from Langmuir–Blodgett to Self Assembly*, Academic Press, New York, 1991.

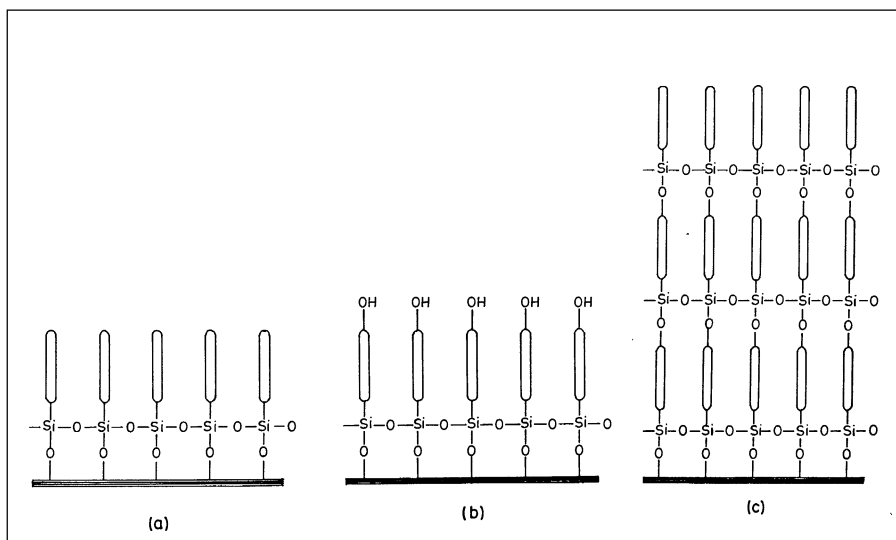

One of the more recent additions to this class of materials is alkane thiol, alkylsulphide and dialkyldisulphide monolayers on Au, Ag and Cu. The sulphur atom chemisorbs on the surface leading to the formation of an alkanethiolate monolayer (RS^- –metal, bonding is between RS^- ion and the metal atom at the surface). The lateral assembly of the R groups makes a compact monolayer. Different kinds of groups have been put on top of the surface. These days almost all functionalities have been made on the monolayer.

How to Study Monolayers on Surfaces

It is not possible to investigate ultrathin films by conventional spectroscopic tools. One cannot take a transmission infrared (IR) spectrum. Similarly, an ultraviolet-visible absorption spectrum in the conventional sense is impossible. The same is the case with nuclear magnetic resonance (NMR) spectroscopy or such other tools. The first experiment one does on monolayers is the contact angle measurement. The contact angle a drop of liquid makes with the surface is an indicator of the chemical nature of the surface. A surface terminated by $-\text{OH}$ and $-\text{CH}_3$ groups will show marked difference in the water contact angle. To measure the thickness of the films, a technique called ellipsometry is used. The principle of ellipsometry is that when a plane polarised light interacts with the surface at some angle, it gets resolved into perpendicular and parallel components. By combining these two components elliptically polarised light results. From the parameters determined from measurements such as the angle of polarisation, the thickness can be calculated. The structure of the monolayers can be obtained from atomic force microscopy and scanning tunneling microscopy. In the simplest form, these are techniques by which the surface morphology can be studied.

An atomic force microscopic image of an alkane thiol monolayer is presented in *Figure 4*. The lighter areas correspond to higher regions and the darker areas correspond to lower regions of the surface. The image is composed of a hexagonal pattern of bright

¹ Reflectance IR and UV spectroscopy as well as grazing angle X-ray diffraction are some of the techniques used for the characterisation of SAMs.



spots corresponding to the alkyl chains. This is indeed the pattern of the arrangement of sulphur atoms on the surface. The distance between the nearest neighbours is 5.2 Å and the next nearest neighbour distance is 9.0 Å. This pattern is very different from that of the underlying gold surface in which the bright spots would be at distances of 2.88 Å.

It is possible to study the arrangement of alkyl chains by diffraction tools such as helium atom diffraction. In this, the scattering of a beam of monoenergetic helium atoms is studied. Although it appears that the alkane chains are perpendicular to the surface they are in fact inclined at an angle (as shown in *Figure 2*). The conformations of the chains and the arrangement of bonds in chains can be studied by reflection absorption infrared spectroscopy. Using polarised light for excitation of vibrational modes, it is possible to understand the tilt of the chains. Limited information along similar lines can be obtained by low energy electron energy loss spectroscopy where energy loss of a monochromatic electron beam upon scattering from the monolayer is studied. The elemental chemical states and the thickness of the films can be studied by photoelectron spectroscopy. Thus a host of surface characterisation tools can be used to understand the molecular details of self assembled monolayers.

3D SAMs

While studying monolayers, scientists realised that many widely used tools cannot be used for SAMs. Take the case of nuclear magnetic resonance spectroscopy (NMR), which may not be easily applied to the study of a film arranged on a surface. If we organise a surface which has unpaired electron spins, it would be ideal to study this by electron spin resonance spectroscopy (ESR). Due to the poor concentration of the species, these studies are difficult. On a flat surface, the number of atoms or groups that can be arranged is $\sim 10^{14}$ per square centimeter. This is far too low compared to the bulk concentration of species ($\sim 10^{23}$). Therefore, in order to use more commonly available

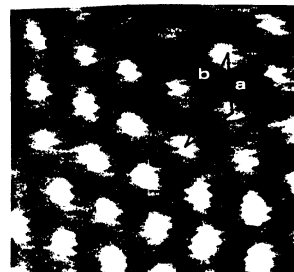
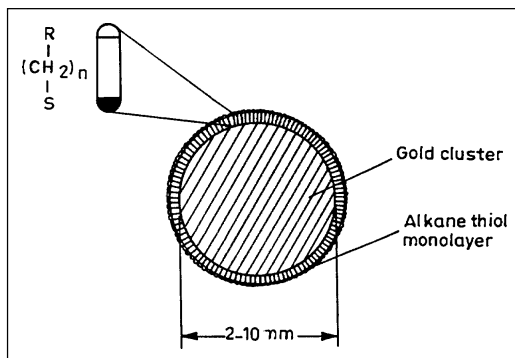

Figure 4. Atomic force microscopic image of an alkanethiol self assembled monolayer prepared on gold. The image has white and dark regions. White represents higher regions and dark represents lower regions at the surface. The distances between the white regions indicate that the image does not correspond to a clean gold surface. *a* and *b* correspond to nearest and next nearest neighbours, respectively. The micrograph is adapted from C A Alves, E L Smith and M D Porter, *J. Am. Chem. Soc.*, 114, 1222, 1992.



Figure 5. A schematic diagram of a cluster assembled monolayer. The metal cluster dimension is of the order of a few nanometers on which a monolayer of about a nanometer length is assembled. This cluster monolayer could be soluble in appropriate solvents depending on the monolayer functionality. These monolayers behave like a molecular compound.



techniques, it is necessary to increase the concentration of the assembled molecules. This is possible if molecules are assembled on metal clusters of a few tens of Angstroms in diameter. This has been recently achieved. Thiols and disulphide monolayers have been made on gold, silver and other metal clusters. A schematic diagram of such a cluster assembled monolayer is shown in *Figure 5*. To differentiate them from the traditional monolayers, some call them 3D monolayers (the common ones are 2D, D stands for dimensional). Now it is possible to study the monolayers by transmission IR. Since the metal cluster monolayer exposes hydrophobic groups at the surface, they can be made soluble in an organic medium just like a molecule so that NMR can be done. These monolayers behave exactly like compounds in the sense that solution phase chemistry can be done on them. Therefore, they are called cluster compounds. On appropriate monolayers, it is possible to use well-known synthetic chemistry approaches to modify the terminal functionality. Chemistry of these systems is rapidly evolving in the past two years or so.

Applications

Of the several kinds of applications suggested, the use of SAMs in nonlinear optics has generated significant research activity. A nonlinear optical material is one in which interaction of light produces a new light of different frequency or phase. Some of the well studied effects are second and third harmonic generation



which means the doubling or tripling of frequency of the incident light. Electron transfer through properly designed molecular assemblies is possible as well as charge transfer excitations between the adjacent molecules. All of these imply immense possibilities. One important aspect is that since the molecules are anchored to the surface, chemistry on one side alone can be done, which makes it possible to make surfaces with desired chemical properties. This would mean developing surfaces for sensor applications and specific catalytic processes. In fundamental processes also, these surfaces are very interesting since this becomes a poor man's single crystalline surface. Such organic single crystalline surfaces can be used for spectroscopy of sorts. Molecular films have been suggested to be used in piezoelectric devices wherein a small change in mass would change the resonance frequency. Such a device can be used as a gravimeter, to measure change in mass. Use in pyroelectric devices to detect light is also visualised. Use of the monolayers as dielectric materials of molecular dimensions have interesting applications. Capacitance of a capacitor is greater when there is a dielectric layer in between the metal plates than when there is air or vacuum between them. Devices in which the films can be used are metal-insulator semiconductor (MIS), metal-insulator-metal (MIM), superconductor-insulator-superconductor (SIS or Josephson junction) junctions and electroluminescence cells, among others. All of these are only possibilities at the moment with self assembled monolayers, but some of them have been realised with L-B films. Conduction through monolayers can have interesting applications in optical switching and photovoltaics. Electrical, thermal and photo induced reversible changes in optical absorption (chromic effects) have also been visualised. Monolayers can be used for chemical sensing applications. On the mechanical front, they can be used to reduce friction on solid surfaces such as in magnetic disks. Monolayers are considered better for this application than conventional liquids because they are supposed to remain on the surface so that the molecules will not migrate from one surface to another (from disk to head for example). Applications also

Numerous potential applications for SAMs can be thought of ranging from catalysis and chemical sensors, to novel electro-optic and NLO devices.



include the development of molecularly thin metal/ oxide layers at surfaces by performing appropriate chemistry. The 3D monolayers can be used as bulk materials. Monolayers can be used to bind metal clusters. Such a polymeric material can be used in applications such as lasers, conducting coatings, catalysts, etc. Chemistry and physics of this class of materials are growing and new applications will be realised in the coming years.

Conclusions

In this article, we saw the evolution of monomolecular films from the early interest in oil films spread on water to self assembled monolayers. The early developments took place in the area of Langmuir–Blodgett films which are films transferred from air-liquid interface to solid surfaces. The more recent development is in the area of self assembled monolayers which refers to monomolecular films of appropriate surfactant formed spontaneously on solid surfaces. These films are thermally and mechanically stable so that a number of applications can be visualised. They can be regarded as organic single crystalline surfaces. Due to the difficulty in probing such 2D monolayers, by conventional tools, monolayers formed on metal clusters – the so called 3D monolayers – are currently being investigated. The chemistry, physics and materials science of this new class of materials will continue to be interesting for years to come.

Address for Correspondence

T Pradeep

Department of Chemistry and
Regional Sophisticated
Instrumentation Centre
Indian Institute of Technology
Chennai 600 036, India

Suggested Reading

- [1] A Ulman, *An Introduction to Ultrathin Organic Films: from Langmuir-Blodgett to Self Assembly*, Academic Press, New York, 1991.
- [2] A Ulman, *Chemical Reviews*, Vol. 96, 1996, 1533.
- [3] G Roberts, Ed. *Langmuir-Blodgett Films*, Plenum Press, New York, 1990.
- [4] R W Murray, et al. *Journal of the American Chemical Society*, Vol. 117, 1995, 12537.

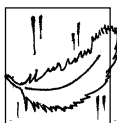

American H S White in 1905

Mathematics is a science continually expanding; and its growth, unlike some political and industrial events, is attended by universal acclamation.

The Mathematical Intelligencer