

What's New in Computers

The CD-ROM

Vijnan Shastri

This article describes the CD-ROM; information storage and retrieval, cost and new applications for the future.

Introduction

You have probably heard of the compact disc read-only memory (CD-ROM) and wondered if it related to the compact disc (CD) that is widely used in music systems. You're right - it is related. But how is it used in computers? Is it identical to the CD-audio? What are its advantages? If it is memory then how much can it store? In the following paragraphs this article answers these and other questions about the CD-ROM and its use as a storage medium for data.

The CD-ROM, like the CD-audio disc, is made of polycarbonate and is 5.25 inches in diameter. Both have a spiral track moving outward from the centre to the periphery where data is digitized and stored. In the case of CD-audio, it is only sound which is digitized and stored whereas in the CD-ROM it is data. This data can be text, still pictures (digitized) or video data (also digitized), audio or a combination of all of them. Digitization of data is the key factor in storing them; which is done as files (unlike CD-audio). Such a file system is needed to organize, store and access the data. The design and format of the file system on a CD-ROM has been standardized by the International Standards Organization and is known as the ISO9660 file system standards.

Pits and Lands

The digitized data (which means that the data is encoded in terms of 1s and 0s) is stored as 'pits' and 'lands' at the bottom surface of the CD-ROM platter (See *Figure 1*). The lands reflect the light from the



Vijnan Shastri works at the Centre for Electronics Design Technology in the Indian Institute of Science, Bangalore, and his areas of interest are digital and microprocessor systems, storage subsystems and systems software.

The design and format of the file system on a CD-ROM has been standardized by the International Standards Organization and is known as the ISO9660 file system standards.



The digitized data (which means that the data is encoded in terms of 1s and 0s) is stored as 'pits' and 'lands' at the bottom surface of the CD-ROM platter.

laser beam and the pits scatter the beam. The optical head consists of a complex arrangement of lenses, prisms and photo-diodes (to detect the light reflections). The optical head arrangement is the same in both the CD-audio and CD-ROM drives. The transition from land to pit or pit to land is coded as '1' and the lack of transition is coded as '0'. The diameter of the laser beam (red laser) is about 670 nano meters. The spiral track is 0.6 micrometer wide with a width of 1 micrometer between spirals. As can be seen in the figure, the layered covering ensures that the life of the CD-ROM is about 100 years (provided it is not badly damaged). The data encoding incorporates a lot of error detection coding (EDC) and error correction coding (ECC) such that even if there are dust particles or minor

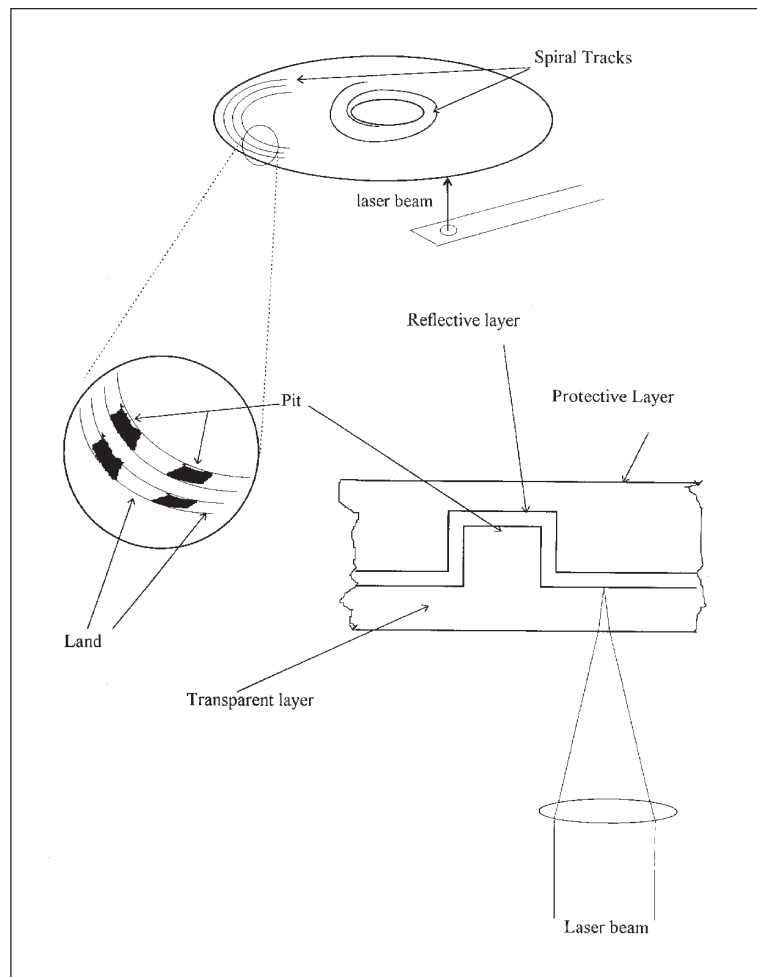

Figure 1 CD-ROM schematic.



scratches, the data can be read off the disc as if these didn't exist.

The CLV scheme

The CD-ROM is itself mounted on a 'turn table' that is driven by a DC servo motor. The important point to note here is that the density of data stored (i.e., of pits and lands per unit length) is constant throughout the spiral. This implies that in order to obtain a constant read-out rate the disk must rotate faster for the tracks near the centre and slower at the outer tracks so as to maintain a constant linear velocity (CLV) between the head and the CD-ROM platter. This is in contrast to magnetic discs which are of the constant angular velocity (CAV) type. In that case the density of data varies: it is more near the centre and less as the head moves outward (again to maintain a constant read-out rate). Research has shown that one can store about twice as much in a CLV type of scheme as compared to a CAV scheme. How much is this data? It is totally 660 Mbytes! This means that about 200,000 pages of the type which you are now reading can be stored on a CD-ROM. The optical head moves radially and the servo motor must re-adjust the rotational speed every time the head moves. The optical head must 'lock' onto the correct part of the spiral once it has moved. Thus the motor control system is a complex one since it has to also respond quickly.

Speed of CD-ROM drives

The success of the CD-audio paved the way for the usage of the CD-ROM in the computer industry for archival storage. Thus until about 1992, the CD-audio drive and the CD-ROM drive had the same motor electronics (and optics) and hence had the same speeds. These were called single-speed drives. Their speed varied from about 300 rpm in the inner tracks to about 500 rpm on the outer tracks. These drives retrieved data at about 150 kbytes/second. Subsequently these single speed drives (although widely used) gave way to double-speed (300 kbytes per second), quad-speed (600 kbytes per second) and now 6X speed (900 kbytes second) drives. These retrieval rates are not required for text-only informa-

About 200,000 pages of the type which you are now reading can be stored on a CD-ROM.

In this multimedia age we need high speed CD-ROM drives to playback video smoothly without jerky movements.



It is not just the data storage capacity of CD-ROMs that is important. This capacity, coupled with the ability of powerful retrieval software running on desktop machines makes the CD-ROM an extremely powerful data storage medium

The cost of 'mastering' (manufacturing) a CD is now well below a dollar. One pays for the data on the platter, not for the platter itself!

tion. But in this multimedia age with information consisting of moving pictures and sound, these data rates are required to playback video smoothly, without jerky movements.

Applications of CD-ROM

Initially CD-ROMs were used for archival storage of text information and text databases. It must be realized that it is not just the data storage capacity of CD-ROMs that is important. This capacity, *coupled with the ability of powerful retrieval software running on desktop machines makes it an extremely powerful data storage medium.* Nowadays they have become popular as distribution media for software as the size of software becomes unwieldy for storage on floppies. However, multimedia capability of desktop PCs has meant that the CD-ROM is the medium of choice to store multimedia data and has spawned a whole gamut of applications. These include multimedia encyclopaedias, multimedia magazines (which the user receives monthly), education aids, and of course multimedia-interactive games. The latter has been enormously successful and is partly responsible for bringing the computer on a large scale into homes of large numbers of people who would not otherwise have bought one.

How much does it cost?

Due to improved manufacturing and mass production concepts the cost of 'mastering' (manufacturing) a CD is well below a dollar. One pays not for the CD-ROM platter but for the data on that platter. Recently, availability of small equipment enabling the production of CD-ROMs without a complex manufacturing setup has brought CD-ROM -based publishing to the desks of a large number of medium and small publishers. This is made possible with the availability of the write -once read-only memory (WORM) discs. The only difference between the CD-ROM and WORM is that CD-ROMs need to be mastered in a manufacturing process whereas WORM discs can be written (albeit only once) like magnetic discs.

Future of the CD-ROM



The CD-ROM has proliferated and has become an integral part of storage hardware, operating in conjunction with magnetic discs, and tapes. The use of more than one layer on a single platter and the development of the blue laser (with a wavelength of 430 nano meters) will mean that CD-ROM capacities will increase to about 3 gigabytes by mid 1997. This storage capacity will mean that it will be possible to store entire full-length movies (at high resolution) on a single CD-ROM and this will naturally spur a host of new applications — especially in the consumer market. With the development of efficient archiving software, libraries of the future will store most of the information on CD-ROM (hopefully helping to save a bit of paper). Users will be able to quickly search, retrieve and perhaps download information they need on their local computers. Remember that this information will include not only text but also sound and moving images. A user wanting to learn about the history of the temples of India will not only be able to read the history, but he/she will also be able to see images of these temples and hear historians talk about them.

CD-ROM capacities will increase to about 3 gigabytes by mid 1997. So a user wanting to learn about the history of Indian temples will not only be able to read the history, but also see images of the temples and hear historians talk about them.

Address for correspondence

Vijnan Shastri
Centre for Electronics
Design Technology,
Indian Institute of Science,
Bangalore 560 012, India.



Francis Crick wrote ... (in *What Mad Pursuit*): "Had Jim (Watson) and I not succeeded, I doubt whether the discovery of the double helix could have been delayed for more than 2 or 3 years In some ways the code embodies the core of molecular biology, just as the periodic table of the elements embodies the core of chemistry, but there is a profound difference — the periodic table is probably true."

