

Robotics

1. Components and Subsystems

J R Vengateswaran



J R Vengateswaran is presently a third year student of the Department of Instrumentation and Control Engineering, Regional Engineering College, Tiruchirapalli. He would like to work in control engineering and its applications in robotics and biomedical engineering.

In this part of the article, an attempt has been made to trace the birth of the robot and the persons who were instrumental in the evolution of the field of robotics into its current state. The basic mechanical features of a robot are also explained.

Introduction

Robot, the American Heritage dictionary says, “is a mechanical device that sometimes resembles a human being and is capable of performing complex tasks on command or by programming in advance”. The Robot Institute of America defines – A robot is a reprogrammable multifunctional manipulator designed to move materials, parts, tools or specialized devices through variable programmed motions for the performance of a variety of tasks. The stress in the above definition lies on the word *reprogrammable*. The robot derives all its versatility and more importantly its adaptability from its ‘computer brain’.

A Brief History of Robots

The basic ability of man to imitate parts of the human body perhaps led to the first robot. A brief history of how robots evolved from being a mere figment of imagination to the working models of today is given in *Box 1*.

Now we have robots that specialize in a wide range of fields. We have automated lawn mower robots, vacuum cleaner robots, robots which play with children, decorative butterflies which keep flapping the wings, robots that learn to live as a colony, wrestle with one another (see www.robotwars.com). We even have frontier prowlers for surveillance near borders of countries and many other machines that save human lives during wars.

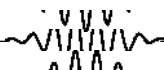

Box 1.

- 1921 Introduction of the term 'robot' into the English vocabulary by the Czech playwright Karel Carpek in his play – Rossum's Universal Robots (RUR).
- 1926 Release of the first movie based on robots – 'Metropolis' in Germany.
- 1939 Display of a walking robot 'Electro and 'Sparko', his dog at the New York World Fair.
- 1940 Claude Shannon built a maze-solving mouse with simple relay circuits and memory to solve the maze with reconfigurable 5x5 array of squares made of aluminium sheets.
- 1947 Geortz developed the first servo controlled electric teleoperator.
- 1948 Force feed back was incorporated into the teleoperator.
- 1949 Research on numerically controlled milling machines took off.
- 1950 Issac Asimov, a well-known author of science fiction wrote '*I-Robot*'. The story revolves around intelligent, obedient humanoid robots.
- 1953 Grey Walter developed 'Tortoise/turtle', a robot capable of detecting moderate light and moving towards it, avoiding obstacles on its way.

The first programmable robot was built by George Devol – 'programmed articulated transfer device'.

- 1956 A commercial manufacturer of robots – Unimation company came into existence.
- 1961 First robot with force feedback information was made.
- 1963 The first robot vision system was developed.
- 1968 R S Moshen developed a quadruped walking truck at the General Electric .

Research on prostheses (replacement of human limbs with mechanical equivalents) was started

- 1969 'Shakey' was developed at the Stanford Research Institute in 1969 – it had the ability to recognize objects using its vision system, reach the object and perform some action on it.
- 1970 'Lunokhod II', a Russian unmanned rover explored the surface of the moon under remote control from earth
- 1971 The 'Stanford arm' took shape at the Stanford University.
- 1973 Stanford came out with WAVE, the first robot programming language.
- 1974 Cincinnati Milacron introduced the T³ robot with computer control.
- 1975 NASA installed a robot arm in the Viking probe to collect Martian soil samples

Late 70's Unimation introduced PUMA robot and Japan, the SCARA robot

Early 80's The first direct drive robot was developed at the Carnegie Mellon University

Having seen the evolution of robots we will now describe the basic components and subsystems of a robot.



Components and Subsystems

The names of various parts of a robot may be thought of as borrowed from their biological counterparts. First, the robot must be mounted on a *base* (or *vehicle*) that may be moving or fixed, depending upon the application. Next, one would expect some mechanical linkages (similar to the limbs of a human) that connect the *end effector* (the final tool with which the robot grasps objects) to the base, with a *wrist* holding the tool.

To control the way the robot works, we need a control system and a supporting measurement subsystem. A power system is required to run the robot. An excellent block diagram representation of the robot system is reproduced in *Box 2* from [1].

Software is a part of almost all the blocks and is not explicitly shown in *Box 2*. For example, the output of a particular sensor may be processed using some software before sending it to the control system, wherein a control software generates an appropriate actuating signal.

Motion

As mentioned earlier, the base of a robot could be either stationary or mobile. Consider a robot that is used in the automobile carrier line. All it needs to do is to sit in one place and fit the various parts of a car (one would find robots that fit only doors or wheels, or weld). So, they need not be provided with a mobile base. On the other hand Rover, Sojourner and the like must be provided with the ability to move around and explore.

Mobility to robots can be given in different ways – legs, wheels or even wings! Each one has its own advantages and disadvantages. Legs can scale varying heights of a surface with ease compared to wheels, but they are shaky. A robot that has less than three legs has to move at a minimum speed in order to maintain its balance; this is called *dynamic stability*. On the other hand, a robot that has at least three legs can maintain *static stability* i.e., stay at the same position and yet be stable. This is

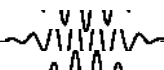

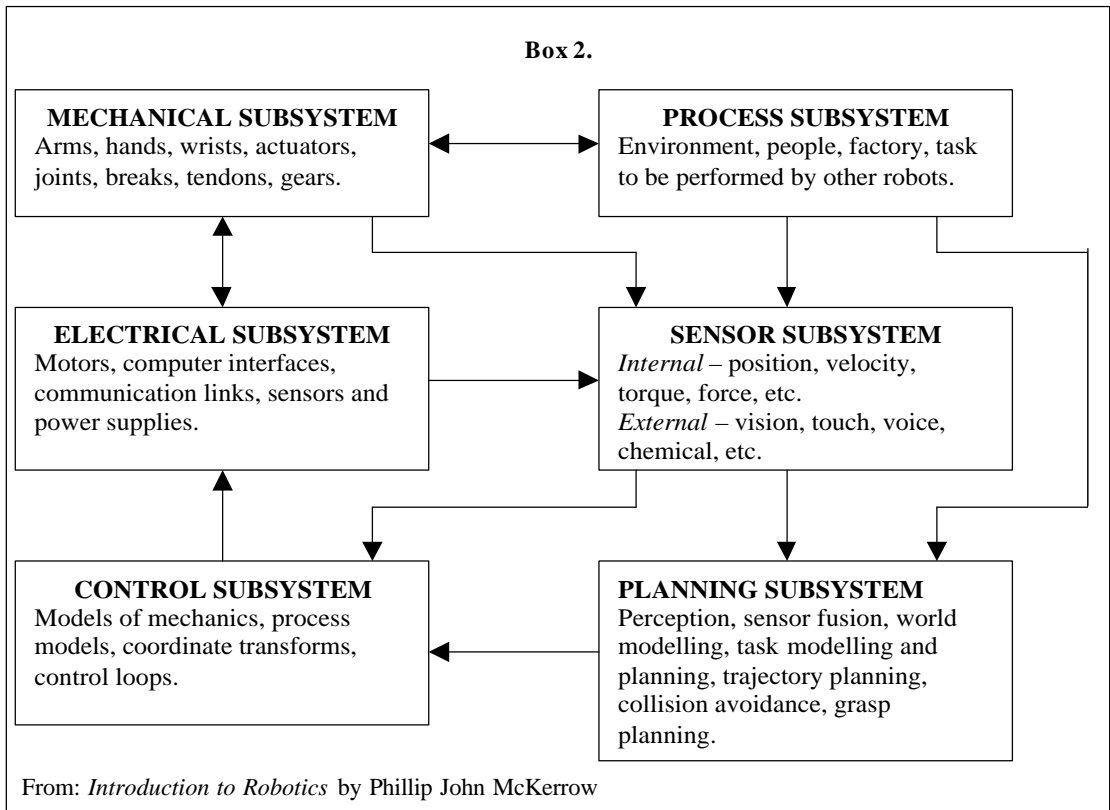

readily seen in a child crawling on all fours and one trying to balance itself while standing up.

An autonomous walking robot must use energy efficiently. For this, the energy supplied by one stride is transferred to the next. Actuator action (that which causes motion of the leg) has been classified into three modes, based on the energy flow:

1. the **positive work mode**, when the actuator supplies force or torque to produce motion.
2. the **isometric mode**, when the actuator supplies a force or torque but no motion is produced.
3. the **negative work mode**, when the actuator supplies a braking force or torque.

Clearly, an actuator that consumes energy in all the three modes is badly designed. The most efficient one is that which saves



energy from the negative work mode to use in the positive work mode.

A recently developed robot leg can neither change its height nor is shaky. It uses a wire (or rod) as a leg and memory alloys as actuators. When heated, the memory alloy (attached to the body) contracts and pulls the leg to which it is tied. This makes the body move forward (the way we walk). On cooling, the alloy restores to its original shape thus restoring the leg to its original position (relative to the body). As the heating-cooling process is repeated, the robot moves forward in steps. This is easily achieved in case of a memory alloy, called nitinol, by passing pulses of current through it. This design, however, can work only when movement is on a surface with sufficient friction.

The wheeled robots are controlled with relative ease and pose fewer stability problems. They could reach greater speeds than the ones using legs. One of the most versatile robots is the *serpentine robot*. The body consists of several segments to which wheels are attached as shown in *Figure 1*. As the name indicates, it moves in a snake-like motion. They are most widely used in places where people cannot manoeuvre or in hazardous environments.

There are various types of wheels available; wheels that rotate as the normal wheels of a car and wheels that are capable of moving sideways like the *Stanford wheel* and the *Illanator wheel*. Refer [1] for further information. Also, various drive and steer arrangements for robots using different numbers of wheels are

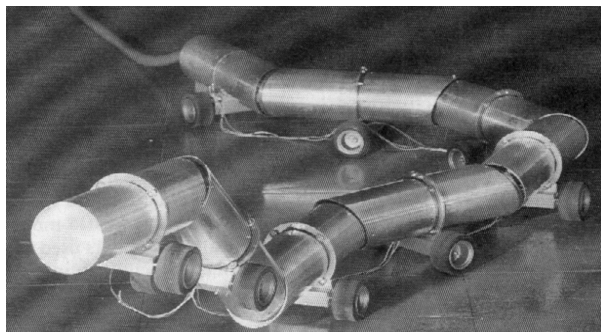
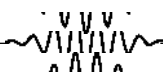

Figure 1. The serpentine robot.

Courtesy: Phillip John McKerrow, Introduction to Robotics.



Box 3.		
Characteristics	Legs	Wheels
Handling of rough surfaces	With ease, smoother ride	With difficulty, rougher ride
Handling of obstacles	Step over	Move around
Sinking into the ground	Less	More
Stability	Lower	Higher
Controllability	Difficult	Easier
Motion	Slow	Fast

possible. For example, a four-wheeled robot can have the front two wheels for steering and the rear two for driving or vice-versa. It can also use all the four wheels for the same purpose. Each configuration has its own pros and cons and the choice depends on the application (see *Box 3*).

If one uses a robot to transport items along a fixed path, then one could lay tracks and restrict the motion of the robot to that path or use *automated guided vehicles* (AGVs). AGVs are robots that can be guided (remotely or self-guided) to a destination through any path. Robots with wings need not necessarily mean that they have wings. It refers to robots that are capable of flying. They may fly by magnetic levitation (the bullet train of Japan!), or glide on air bearings. Research is on to develop robot helicopters that can fly all by themselves in any area and also generate a map of the area. The army could then use these robots for strategic surveillance.

Manipulator Arms

Robot manipulators are composed of links connected by joints. The joints may be either *revolute* [R] or *prismatic* [P]. A revolute joint allows rotary motion, while a prismatic joint allows linear motion. The number of independent movements the manipulator can make with respect to a coordinate frame is defined as the *degrees of freedom* (DOF) of the manipulator, which can be determined by the number of joints in it.

The most commonly used arm consists of three links, as shown in *Figure 2*. It has six degrees of freedom – three for positioning

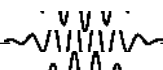

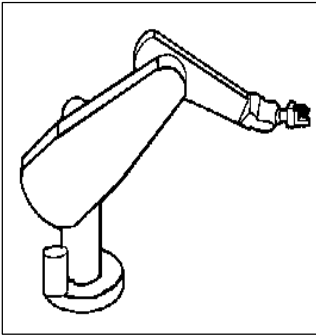

Figure 2. Manipulator arm with three limbs.

Courtesy: Phillip John McKerrow, *Introduction to Robotics*.

and three for orientation. The first link performs the functions of a human torso and rotates around the waist joint. The second link is the upper arm and is connected to the torso by a shoulder joint. The third one is the forearm, connected to the former manipulator arm with three links by an elbow joint. Then comes the wrist holding the end-effector.

The manipulators are usually classified kinematically on the basis of the arm or first three joints, with the wrist being described separately. The manipulators fall into one of the following five geometric types: *Articulated* (RRR), *spherical* (RRP), SCARA (RRP), or *Cartesian* (PPP). The wrist again has its own degrees of freedom and the most versatile wrist is obviously one with three degrees of freedom. Interested readers are urged to refer [2] for further details. For more on wrist actuators, see [6].

In the next part we will discuss the instrumentation and control of robots.

Suggested Reading

- [1] Phillip John McKerrow, *Introduction to Robotics*, Addison-Wesley, 1991.
- [2] Mark W Spong and M Vidyasagar, *Robot Dynamics and Control*, John Wiley, 1989.
- [3] J J Craig, *Introduction to Robotics: Mechanics and Control*, Addison Wesley, 1986.
- [4] Klafter and others, *Robotic Engineering: An Integrated Approach*, Prentice Hall of India, 1993.
- [5] Mark Elling Rosheim, *Robot Evolution: The Development of Anthrobotics*, Wiley, 1994.
- [6] Mark Elling Rosheim, *Robot Wrist Actuators*, Wiley, 1989.

Address for Correspondence
J R Vengateswaran
Department of Instrumentation
and Control Engineering
Regional Engineering College,
Tiruchirapalli 620 015, India.

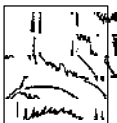

We are evaporating our coal mines into the air. Adding so much carbon dioxide gas to the air must be causing “a change in the transparency of the atmosphere”

Arrhenius

London, Edinburgh, and Dublin Philosophical Magazine

April 1896.

