

host. Usually cattle and rarely buffaloes are infected, but sporadic cases occur in goats. One case of equine infection was brought to the notice of the author. A thorough description of both the male and female parasite was first given by Bhalerao (1932). According to the available data the disease occurs in Bombay, Madras, Central Provinces, Bihar, Assam, Orissa, Mysore, Bengal and also in Burma. Antimony tartrate is the drug of choice for the treatment of this infestation.

Prior to 1932, *S. indicum* was known to occur only in the horse, donkey, sheep and camel, when Bhalerao (1932) recorded its presence in cattle and goats from various localities in India. Montgomery was the first to describe this species, later Bhalerao (1932) added materially to the original description of this parasite. The life-history of this important parasite still awaits elucidation.

Chandler (1926) recorded from the supposed human stool asymmetrical schistosome eggs with a subterminal spine, and assigned these ova to a new human species of schistosome—*Schistosoma incognitum*. In addition to porcupine hosts, *S. incognitum* parasitises dogs as well.

Ornithobilharzia bomfordi was found only once in a plain cattle at Mukteswar by Montgomery. Along with *S. spindalis*, Price (1929), assigned this species to the genus *Ornithobilharzia*, remarking that some birds must have been the definitive host of this species and that bovine infection was purely accidental.

Madaliar and Ramanujachari (1945) identified a species from the elephant and designated it *Schistosoma naini*. On account of the anatomical peculiarities of both the male and female worms, this species could not be retained in

the genus, schistosoma, and Bhalerao assigned it to *Ornithobilharzia* in 1947.

There are a few records in this country of indigenous human schistosomiasis. Mello (1936) quotes one definite case of urinary bilharziasis in a child who showed numerous ova of *S. hæmatobium* in urine and fæces. Recently Andreasen and Suri (1945) reported a case where large number of ova of *S. hæmatobium* were detected in urine.

From the scanty report, it would appear at the first sight that human bilharziasis is not a very serious condition in this country. It, however, transpires that some molluscs in this country are capable of harbouring the larval stages of the human schistosome, *S. hæmatobium*, and this fact offers a clue to explaining the sporadic occurrence of the cases of bilharziasis in this country. This need not, however, alarm us, for the clinical, epidemiological and experimental data, obtained so far, do not warrant the conclusion that urinary bilharziasis may become endemic in India.

Cort (1928) was the first to demonstrate that non-human schistosome cercari produces the "swimmer's itch". Bhalerao recently encountered similar conditions in men bathing in some tanks in the Mysore State. Examination of the snails from the tank revealed the presence of two species of cercariæ.

Bhalerao concludes by saying that schistosomiasis, particularly in domestic animals is a very serious condition and causes considerable monetary loss to the stock-owner in this country. Strenuous efforts should, therefore, be made to control this condition. Such measures will not only eliminate schistosomiasis but will also exterminate other fluke diseases, both of men and animals existing in this country.

N. N. DE.

BETA-RAY COUNTERS

R. S. KRISHNAN

(Department of Physics, Indian Institute of Science, Bangalore)

I. INTRODUCTION

IONISATION chambers and Geiger counters are very frequently used for detecting and measuring the radiations emitted by artificial radio-active bodies. Although ionisation chambers are easily made they are not suitable for measuring very weak β or γ -rays, since a limit to the measurement of very weak radiations is set by the background ionisation or rather by its statistical fluctuations. For reliable measurements with ionisation chambers and electroscopes, the source should be much stronger than that required for measurements with counters. Moreover, ionisation chambers are not useful for studying nuclear isomerism and K-capture by the coincidence method, whereas Geiger counters are indispensable for such studies. Much work has been done and many papers have been published on the construction and performance of Geiger counters. But often contradictory views have been expressed by workers in different laboratories. In connection with the investigations on the deuterium-induced disintegrations in the heavy elements,

the author studied in some detail the methods of construction and behaviour of counters suitable for measuring β -ray activities of radioactive products. The results of these studies which were carried out in the Cavendish Laboratory at Cambridge (which are not at all outmoded now) are presented in this article.

2. THE MECHANISM OF EXTINCTION IN COUNTERS

The counter is essentially an ionisation chamber in which the intensity of the electric field is such that a discharge does not set in spontaneously but is started by the ionisation produced by the incoming particles. The discharge thus produced is not allowed to become permanent, but is interrupted automatically after a very short time in order that the apparatus may be reset in a proper condition for registering the next particle. The point and the tube counters work on the same principle, although the tube counter is more sensitive than the point counter. The sensitivity of the counter is not very much influenced by the energy of the particles counted.

Fig. 1 (a) shows the electrical connections of a counter and Fig. 1 (b) is a typical characteristic curve for a counter. V_1 is the voltage at which the counter begins to record impulses. From $V_{min.}$ to $V_{max.}$ the number of counts recorded with a given radio-active source remains constant. When the voltage is increased above $V_{max.}$ the number of impulses increases very rapidly until at V_2 a steady discharge takes

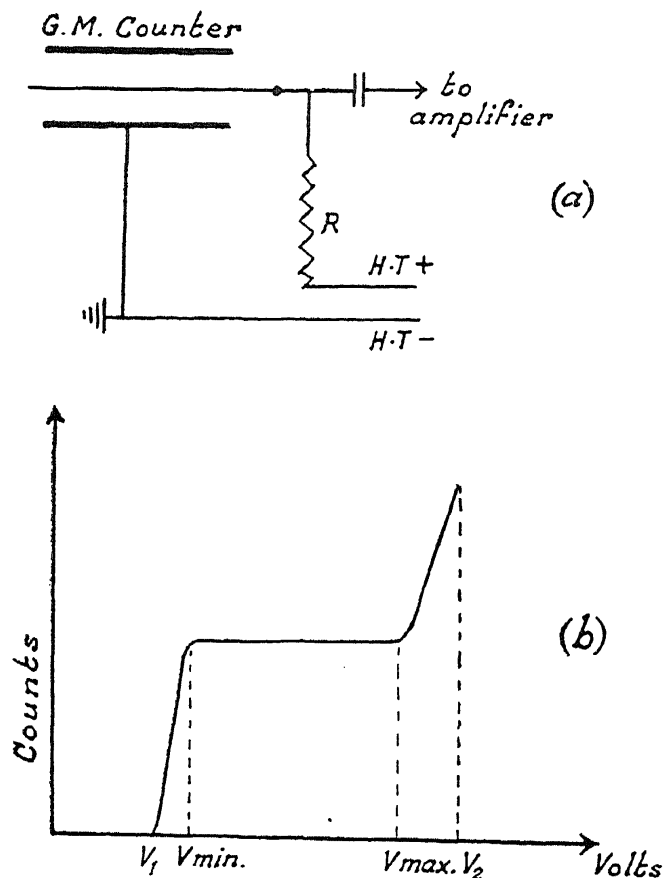

FIG. 1

place. In the absence of the resistance R (Fig. 1a), continuous discharge sets in as soon as the voltage is raised to $V_{min.}$ It has been shown by Werner¹ that if a resistance R is introduced in the circuit, a permanent discharge can occur only if the voltage applied to the counter is greater than $V_{min.} + I_{min.} \times R$ where $I_{min.}$ is the minimum current required for a discharge and is characteristic of the counter under investigation. $V_2 - V_{min.} = (I_{min.} \times R)$ gives a measure of the counting region. When the applied voltage lies between V_2 and $V_{min.}$ during a discharge the counter voltage falls below $V_{min.}$, and the discharge is interrupted. The voltage across the counter rises again to the full value of the high tension supply and the counter is ready for registering the next incoming particle. The region of constant rate of counting, i.e., $V_{max.} - V_{min.}$, is only a part of the counting region. In order to have this region sufficiently large, R should be of the order of 10^8 to 10^9 ohms.

As is well known, the use of a very high resistance is rather a disadvantage in working with counters. Firstly the preparation of such resistances is not very easy. Secondly it sets a limit to the maximum permissible counting rate. After the passage of the discharge and the consequent fall in voltage across the counter, it is practically out of action for

a time $t = t_g + t_{re}$, where t_g is the duration of the discharge and t_{re} is the time taken by the counter for the voltage to rise above $V_{min.}$ so as to make the counter active again. The time t_{re} , depends on R as well as on the capacity of the counter and is of the order of 10^{-2} sec. for $R = 10^9$ ohms. The net result is that particles would be missed from being recorded at high counting rates. One way of avoiding this difficulty is to use a special circuit suggested by Neher and Harper.² In this the extinction is effected by a valve. Another way of avoiding most of the difficulties is to use a self-extinguishing counter which was first developed by Trost.³ He showed that counters filled with argon and alcohol vapour had a reasonably wide counting range which was independent of the external resistance, and hence the resolving time could be made very small.

3. CONSTRUCTION OF BETA-RAY COUNTERS

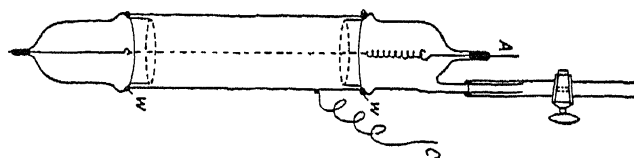

FIG. 2. Thin-walled Geiger-Muller counter
A = anode, C = Cathode, W = Wax seal

Thin-walled Geiger tube counters of the type shown in Fig. 2 were extensively used for measurements of β -ray activity. A thin metal tube of copper or aluminium (0.1 mm. thick) acted as cathode. In these counters the β -ray has to pass through the metal wall of the counter before it is detected. Due to the finite thickness of the wall, particles of energies below a certain value would be absorbed. Such counters are, therefore, not useful for measuring β -rays of low energy.

In order to measure the activity of substances emitting beta particles of low energy, the author developed some special types of counters. The most satisfactory one is shown

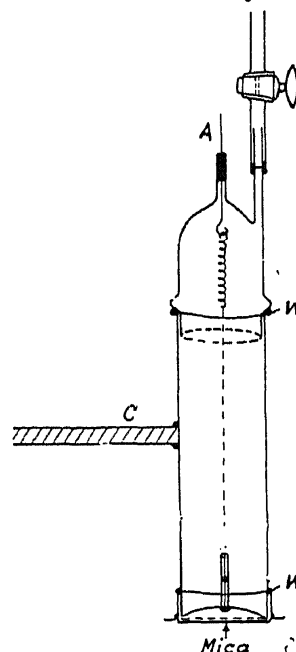

FIG. 3. Grid counter

in Fig. 3. This type was a slightly modified form of that used by Dr. Feather.⁴ The coun-

ter was made up of a brass tube to one end of which was fixed a curved bridge with a hole in the middle. Through this hole passed a pyrex tube with a bead at one end. Into this narrow pyrex tube was fused one end of a piece of tungsten wire (50μ in diameter). The other end of this wire was attached to a tungsten hook through a tungsten spring in order to keep the central wire under tension. The tungsten hook was fused to a pyrex glass cap which was fixed to the brass tube with picein wax as shown in the figure. That end of the brass tube which held the bridge was closed by means of a brass cap provided with a grid. A piece of thin mica film (2 cm. air equivalent) was stuck on the grid. With this arrangement the counter could be made vacuum tight and at the same time the beta particles could enter the counter through the mica window. The pyrex glass cap was provided with a side tube and a glass tap for purposes of evacuation and filling in with gas. The counter was supported by means of a $3/16$ " rod soldered to the body of the brass tube. The counter was usually mounted vertically with a standard adapter for specimen holders fixed at a defi-

radio-active sources could be removed from under the counter and brought back again exactly to the same position for counting.

Before assembly the parts of the counter were cleaned as follows:—The brass tube was well polished on the inside using the finest emery paper available and the dust from the inside was removed by running tap water under pressure through the tube. It was finally rinsed with distilled water and dried. The inside as well as the outside of the brass cap was well polished before fixing the piece of mica. The pyrex cap was cleaned by washing it with hot chromic acid and finally with distilled water. The 50μ tungsten wire which formed the anode was cut from a fresh spool, washed with benzene and alcohol and was heated to a dull red heat in a small flame. After assembly, the counter was evacuated and was filled with pure argon and absolute alcohol vapour in the ratio of 9:1 to make up a total pressure of 10 cm. of mercury. This ratio was first suggested by Trost.³ A counter constructed on the lines indicated above gave a good characteristic with the counting region extending well over 300 volts.

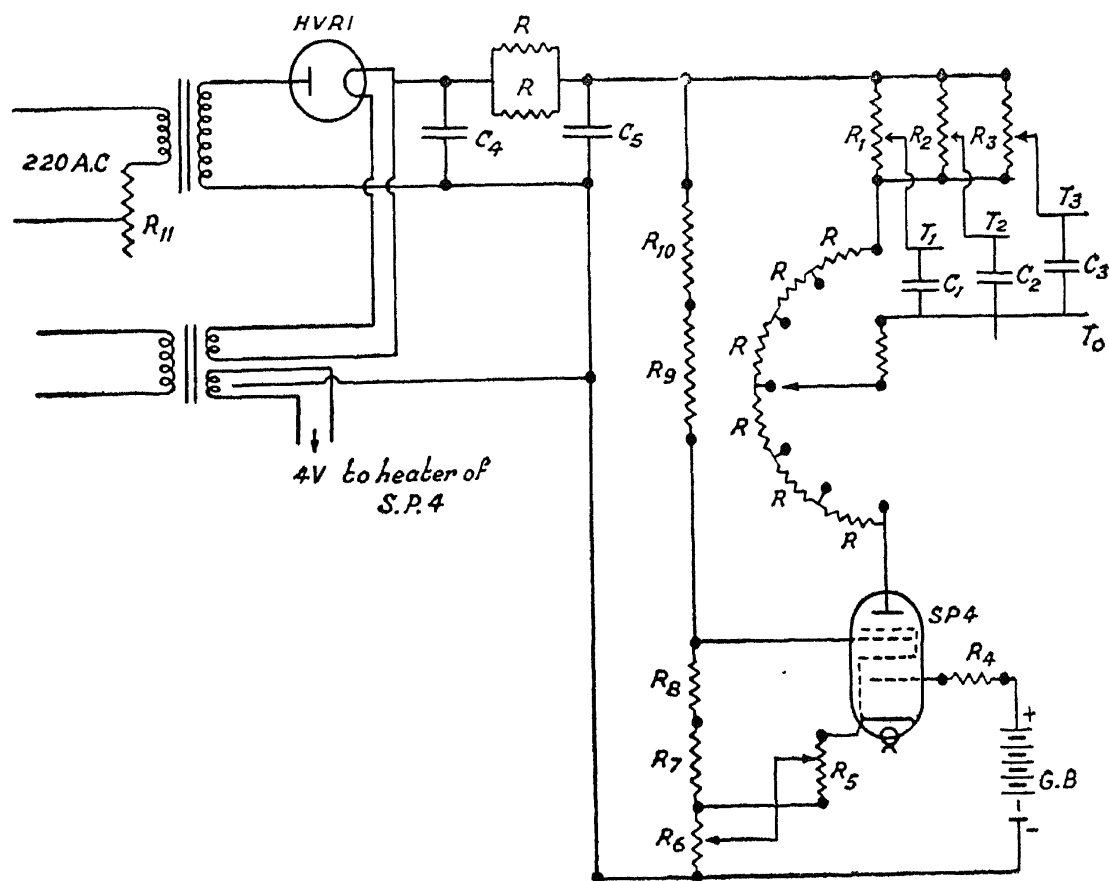

FIG. 4. Stabilised high tension unit for Geiger counters.

$R=250,000$ ohms; R_1, R_2 and $R_3 =$ one Megohm each; $R_4 = 2$ Megohms; $R_5 = 25,000$ ohms (variable), $R_6 = 15,000$ (variable); $R_7 = 50,000$ ohms; $R_8 = 100,000$ ohms; $R_9, R_{10}, R_{12} =$ each one Megohm; $R_{11} = 400$ ohms; $C_1, C_2, C_3, C_5 =$ each $0.1 \mu F$; $C_4 = 0.2 \mu F$. T_0, T_1, T_2 and $T_3 =$ output terminals.

nite distance from the former. The specimen holders were made of brass and were of the same standard size. They were provided with standard cups for holding the radio-active sample. The whole arrangement was such that the

4. HIGH TENSION UNIT

A stabilised high tension unit with the output varying from 0 to 1,500 volts forms an integral part of any counting system using a Geiger counter. Many circuits using vacuum

tubes for stabilising the output voltage have been described in the literature. The circuit adopted by the author for the construction of the stabilised high tension supply was the one suggested by Lewis.⁵ It is shown in Fig. 4.

It is a slightly modified form of Street and Johnsons' circuit.⁶ The stabilisation of the output voltage was effected by a pentode. R_5 was the standardising resistance. This, in conjunction with the bias battery, could be adjusted to give 1 mA. stabilised current so that each step on the range switch was equal to 250 volts and the control resistance, R_1 , R_2 or R_3 also covered about 300 volts. Stabilisation was made by adjusting R_4 . The stabilising action could be tested by changing the input volts by varying the test stabilising resistance R_{11} , while measuring the output with an electrostatic voltmeter. The high tension supply was provided with threeappings coming from the three control resistances, R_1 , R_2 and R_3 . This was quite useful for doing work on double or triple coincidence. Three counters could be supplied with the necessary voltages from the same set, provided the operating potentials did not differ from one another by more than 250 volts.

5. AMPLIFIER

The counter was coupled to a single stage amplifier as shown in the accompanying Fig. 5. The amplifier was both a single stage

ses were reasonably sharp with an average resolving time of 10^{-4} sec. The resolving time of the whole counting system was determined by the well-known coincidence method. Two identical counters were connected to two valves of the amplifier mixer circuit and two separate sources were placed under the counters. The two counters were well protected from each other so that the electrical impulses from one did not influence the working of the second one. The number of counts registered by each counter was recorded first and then the accidental coincidence rate was determined with and without the sources under the counters. The finite resolving time t of the counting set was calculated from the formula,⁷

$$A = 2 N_1 N_2 t + c,$$

where A is the number of chance coincidences per sec., N_1 and N_2 are the number of counts per sec. recorded by each counter separately and c is the number of coincidences due to penetrating radiations alone. The chance coincidence rate A was determined for various values of N_1 and N_2 and the finite resolving time t was evaluated from the above formula after eliminating c . The resolving time was less than 10^{-4} of a second.

7. EFFICIENCY OF THE COUNTING SYSTEM

Before using any counting system consisting of a Geiger counter, amplifier and the scale of eight for quantitative measurements, it is neces-

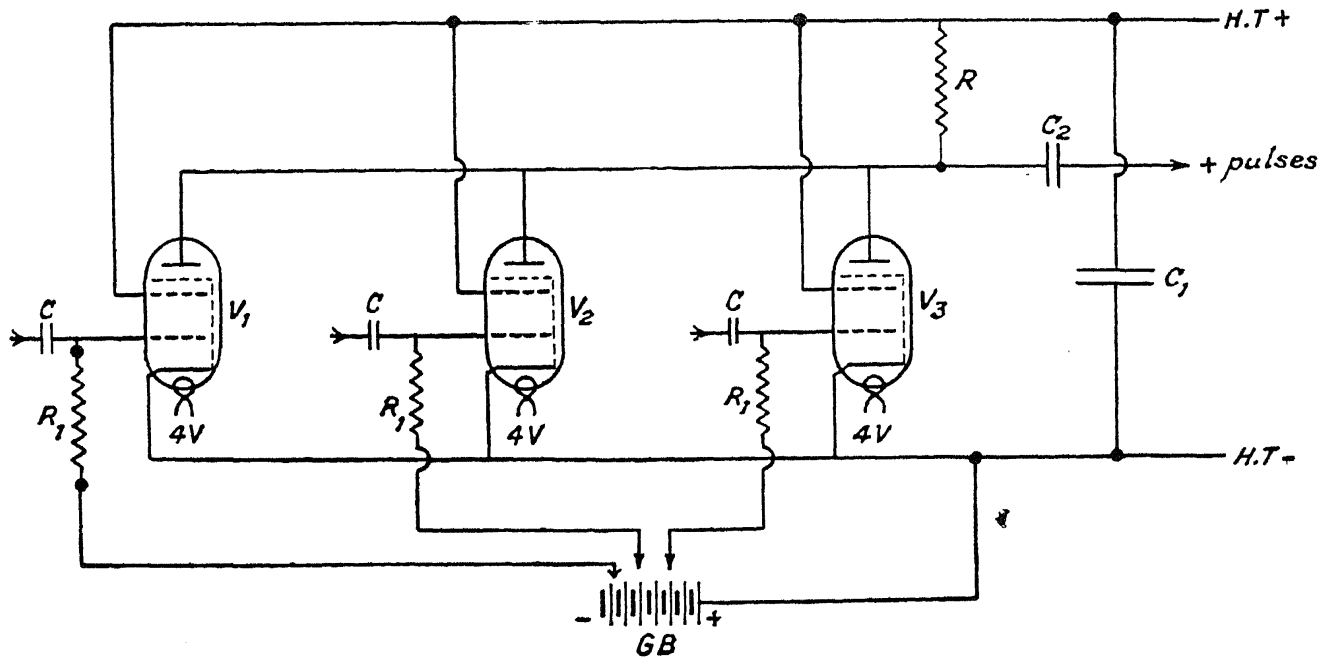

FIG. 5. Amplifier and Rossi mixer circuit for Geiger counters.

$R = 10$ Megohms; $R_1 = 2$ Meg. ohms; $R_3 = 30,000$ ohms; $C_0 = 50 \mu F$; $C_1 = 4 \mu F$; $C_2 = 0.01 \mu F$.

amplifier and a Rossi mixer circuit useful for coincidence work. It was mainly used as a single stage amplifier keeping the grids of the second and third valves heavily biased. The output from the amplifier was fed on to the discriminator of a thyratron scale of eight circuit.

6. RESOLVING TIME OF THE COUNTING SET

The nature of the impulses produced in a good counter constructed as per details given in Section 3, was visually examined with the aid of a cathode-ray oscillograph. The impul-

sary to determine its overall efficiency. The efficiency of the recorder system used by the author was estimated by feeding in a known number of counts having a random distribution. Seven different capsules were taken, and into each was put some uranium oxide sufficient to give about 100 counts per minute. These capsules went into specified holes in a specimen holder which were marked 1, 2, 7. Capsules, when used, were placed in their respective holes and counts given by each individually were determin-

ed. The calibrated sources were then used in combination and the sum of the individually determined values was taken as the true input. In this method the sources were so weak that the counting losses from any one source

TABLE I

Capsules	Count /min. observed	Counts/min. calculated	% Difference
1	84 ± 5		
2	128 ± 5		
3	106 ± 5		
4	140 ± 6		
5	110 ± 5		
6	171 ± 6		
7	108 ± 5		
1 2	209 ± 7	212 ± 7	-1.5 ± 4.5
1 2 3	315 ± 8	318 ± 8.5	-1 ± 3.5
1 2 3 4	440 ± 9	451 ± 10.5	-4 ± 3
1 2 3 4 5	573 ± 4	568 ± 12	+1 ± 2
1 2 3 4 5 6	726 ± 13	739 ± 13	-1.8 ± 2.5
1 2 3 4 5 6	7873 ± 13	880 ± 14	-0.8 ± 2

were assumed negligible. Table I gives the experimental and the calculated values of the counts. The error for the sum was calculated from the formula $e = (e_1^2 + e_2^2)^{1/2}$ where e_1 and e_2 were the errors in the two sets of counts when measured individually.

As would be evident from the table, for counts up to 900 per min. the efficiency of the counting system was very nearly 100 per cent.

The method was extended to higher counting rates. The seven capsules were filled with uranium oxide, each sufficient to give about 900

efficiency steadily decreased and at 5,000 particles a min. the efficiency was about 95 per cent. When the number exceeded 7,000 a min., the mechanical meter attached to the scale of eight unit got jammed. The low efficiency of the counting system was due to the fact that the mechanical meter used was a very old and heavy one.

8. COUNTER CHARACTERISTIC

A large number of counters of the type shown in Fig. 3 were constructed. The characteristic of a good one is reproduced in Fig. 6. Curve *a* represents the total counts, curve *b* the natural of the counter and curve *c* the net counts due to the radioactive source alone. Uranium oxide was used as a standard source. As would be evident from the curves, this counter had a flat portion extending from 950 to 1,250 volts over which the number of counts recorded remained constant. While taking measurements, this counter was usually worked at a potential of about 100 volts above the starting voltage. The counters with mica windows had a natural count varying from 20 to 40 per min. In most cases the natural was not affected by bringing a strong source for measurement. In order to check whether the counter was behaving properly, the natural of the counter and also the strength of a standard uranium source were measured at frequent intervals. The characteristics of counters with mica windows, if properly made, remained satisfactory for periods extending over a year or more.

The effect of the partial pressures of argon and alcohol on the counter characteristic was studied and the best characteristic was obtained when the partial pressures of argon and alcohol were in the ratio of 9:1. The value of the quenching resistance was found to have no appreciable effect on the characteristic of a counter filled with argon and alcohol, although it affected the size of the pulse transferred to the amplifier. These results were in accordance with the observations reported by Trost³ and Curran and Petrzilka.⁸ It was found that if the pyrex glass cap was replaced by a cap of soft glass, spurious pulses were recorded due to electrical leaks.

9. SOFT β -RAY COUNTERS

Radioactive isotopes having very long periods are in general very weakly activated, and the radiations emitted by them are often very soft. An ordinary counter in which the particles have to pass through a mica window of thickness equivalent to about 3 cm. of air, before entering the counter is not very efficient for detecting and studying the soft radiations emitted by weak radioactive bodies. A special type of counter suitable for the study of the soft β -ray spectra was constructed by Libby and Lee.⁹ Two types of soft counters of simple design were constructed by the author, one of which was used for detecting and measuring the half periods of radioactive isotopes, while the second was employed for the measurement of absorption in aluminium of the radiations emitted. In both the types the active substance was placed inside the counter.

The counter of the first type is shown in Fig. 7. It is substantially the same as that

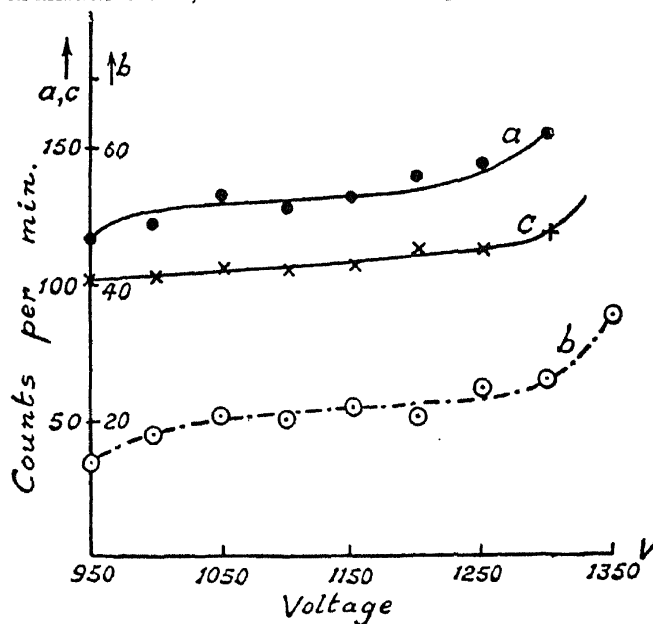

FIG. 6. Characteristic of a Geiger counter

counts per min., and the experiments were repeated. It was found that with the counting system used by the author, the losses became appreciable when the number of particles counted exceeded 2,000 a min. The counting effi-

shown in Fig. 3. Instead of the grid cap it was provided with a glass collar and a ground-in stopper which carried the specimen holder. After inserting the active substance into the

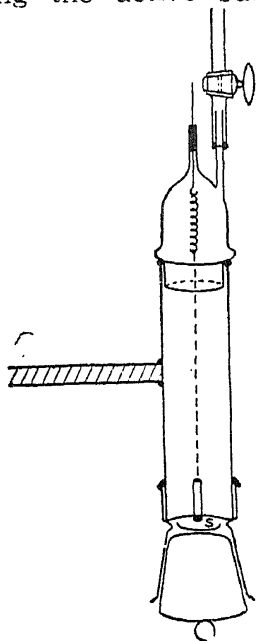

FIG. 7. Soft β -ray counter. S = specimen holder.

counter, it was evacuated and filled with the required amount of argon and alcohol. The absorption was almost negligible inside. In a counter of this type the natural characteristic had to be determined beforehand. After inserting the substance and filling the counter with argon and alcohol, the counter potential was set at the predetermined value, and the activity was measured. The chief drawback in counters of this type was that the natural, the counts due to some standard source and the counts due to radioactive sample under examination could not be measured simultaneously without opening the counter, evacuating and filling it

The defect mentioned above was, however, eliminated by adopting the following modification in the construction of the counter. The counter part was housed on a side tube attached to the middle portion of a wide glass tube about 9" long. One end of this tube was drawn out and fused, while the other end was closed by means of a rubber stopper. A steel rider slid along a rod which was fixed axially inside the wide glass tube. The rider was four inches long and at its two ends were fixed two specimen holders, one for the radioactive sample under investigation and the other for a standard source. The rider could be moved along the rod by means of an electromagnet. By placing the rider symmetrically below the counter, its natural was determined. The reliability of the counter was checked by taking measurements with the standard source at frequent intervals.

For absorption measurements of very weak radiations either soft β -rays or soft X-rays, the counter shown in Fig. 8 was developed by the author. The counter part was similar to that shown in Fig. 2 with the difference, namely, that the cathode cylinder was made of fine copper gauze. The counter was mounted horizontally inside a pyrex bell-jar. The glass cap of the counter was fitted into the side tube which held the counter in position. The radioactive preparation was placed inside a specimen holder, S, which was fixed to the stopcock. Aluminium absorbers were mounted on a drum which was provided with sufficient number of apertures. The drum was capable of rotation by means of a handle, H, which could be operated from outside. A paper scale was fixed on the drum and a mark was made on the top of the bell-jar. By turning the handle, H, and noting the position of the mark on the scale, any particular absorber could be brought over the source. One of the absorbers

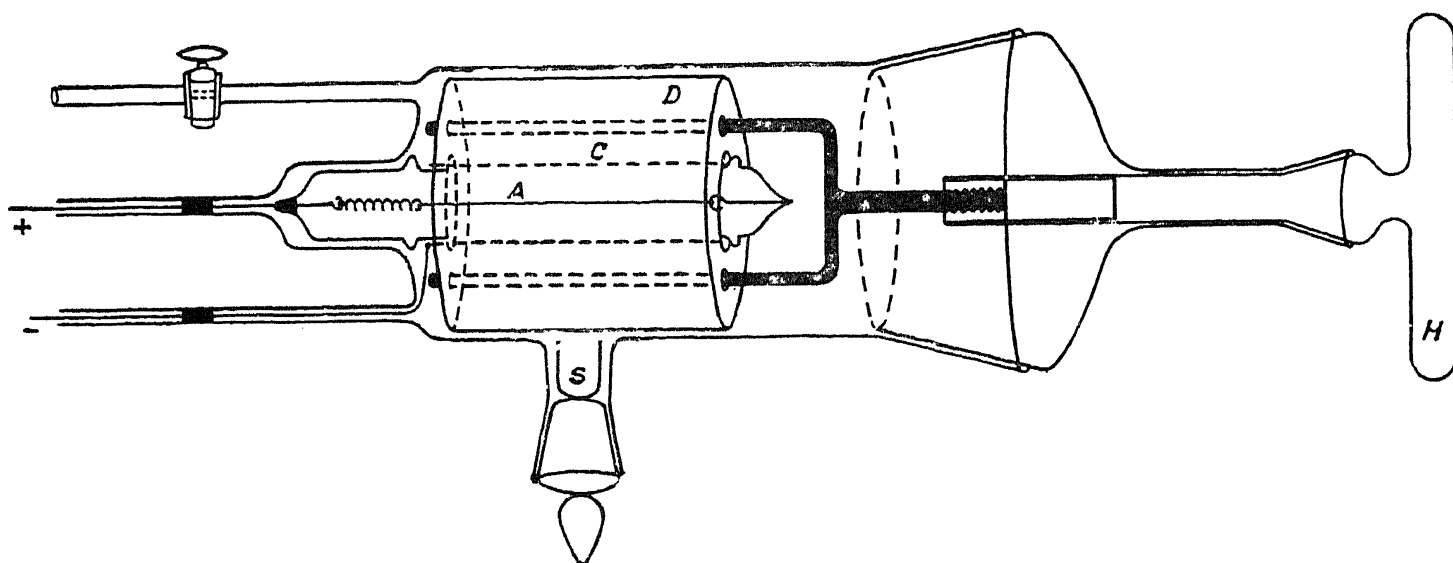

FIG. 8. Demountable soft β -ray counter. A = anode, C = cathode; D = drum containing the absorbers; S = specimen holder and H = handle for rotating the drum.

every time with alcohol-argon mixture. It was found that if sufficient care was taken in letting in dust-free air and if the counter was not unduly exposed to the atmosphere, the natural as well as the characteristic of the counter could be reproduced within the limits of experimental error.

was of lead with a thin aluminium foil over it. The thickness of the lead foil was such that it was capable of effectively cutting off soft X-rays and the aluminium foil over it would absorb the photo-electrons ejected from the lead absorber. The specimen holder was in the form of a tall cylindrical box and the size of the

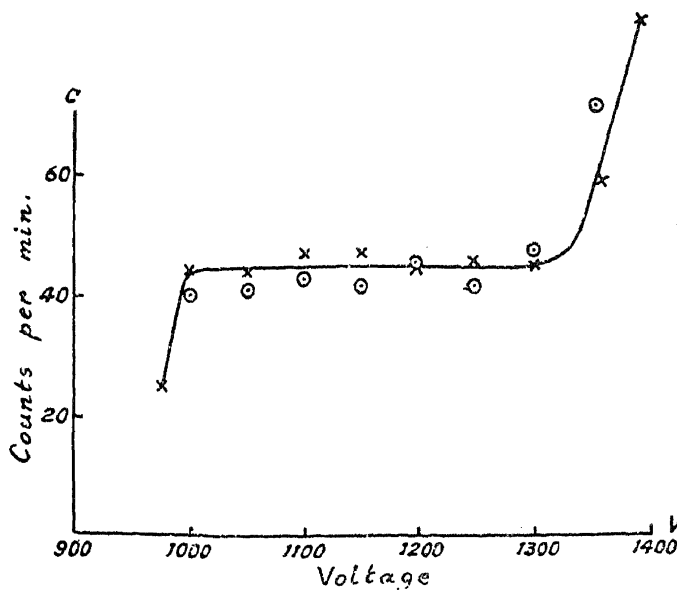

FIG. 9. Characteristic of a demountable soft β -ray counter. Circles—when the counter was first assembled. Crosses—after two months of use. drum was such that the absorbers formed a cover for the specimen holder. This prevented

the particles emitted by the radioactive source getting away through the sides and finally finding their way into the active region of the counter and giving spurious results. The cylindrical form also helped to canalise the particles.

A counter constructed on the lines indicated above worked quite satisfactorily and its characteristic is shown in Fig. 9. This counter was successfully used for measuring the absorption in aluminium of the soft electrons emitted by the 6.7 hr. and 1 year cadmium isotopes.

1. Werner, *Zeits. f. Phys.*, 1934, **90**, 334, 1934, **92**, 705.
2. Henning and Schade, *Zeit. f. Phys.*, 1934, **90**, 597.
3. Neher and Harper, *Phys. Rev.*, 1936, **49**, 940.
4. Trost, *Zeit. f. Tech. Phys.*, 1935, **16**, 407. *Phys. Zeit.*, 1935, **36**, 801. *Zeit. f. Phys.*, 1937, **105**, 399.
5. Feather, *Camb. Phil. Soc. Proc.*, 1938, **34**, 115.
6. Lewis, *Journ. Sci. Instruments*, 1938, **15**, 353.
7. Street and Johnson, *Journ. Frank. Inst.*, 1932, **214**, 155.
8. Feather and Dunworth, *Proc. Roy. Soc. (A)*, 1938, **168**, 566.
9. Curran and Petrzilka, *Proc. Camb. Phil. Soc.*, 1939, **35**, 309.
10. Libby and Lee, *Phys. Rev.*, 1939, **55**, 245.

Note.—The cost of printing this contribution has been met from a generous grant from the Rockefeller Foundation for the publication of results of scientific work made to us through the kindness of the National Institute of Sciences, India.

TTT-CURVE DATA AND THEIR APPLICATION

G. P. CONTRACTOR

(National Metallurgical Laboratory, Council of Scientific and Industrial Research)

SINCE the publication of the original paper by Davenport and Bain¹ in 1930 much interest has been shown by metallurgical workers in the study of isothermal transformation of austenite. Investigation on the effect of alloying elements and the nature of austenite on the position of the S-curve have added to our knowledge of the mechanism of the kinetics of the transformation in austenite. The original steels investigated by Davenport and Bain¹ gave curves of such a shape as to suggest the term S-curve for this type of isothermal transformation. Since then, alloy steels have been investigated in which there

are three temperature ranges of rapid transformation, instead of two as on the plain carbon steels, and those are not in any way suggestive of the letter 'S'. Figs. 1 and 2 respectively

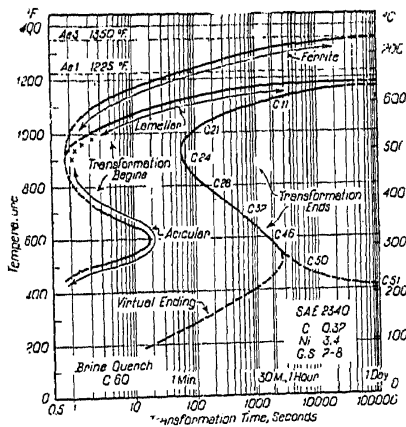

FIG. 1. Isothermal transformation curve for S. A. E. 2340 steel (Ref. 6).

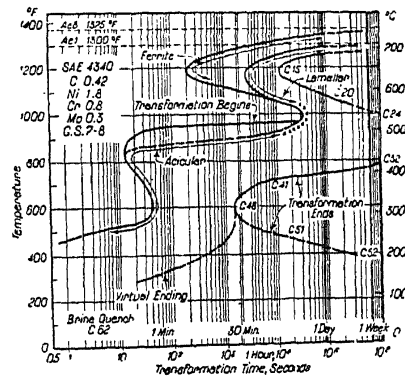

FIG. 2. Isothermal transformation curve for S. A. E. 4340 (Ref. 6).

show these two types of curves. The term "isothermal transformation diagrams" and "TTT-curves" (time-temperature-transformation curves) also have the same meaning as the term S-curve. The term TTT-curve has been adopted in this contribution.

This paper is prepared with a view to assembling important features on TTT-curves and their applications and interpretation. The purpose has been to indicate its applicability in heat treatment of steels,