

THE ELECTROSTATIC GENERATOR FOR NUCLEAR DISINTEGRATION

BY

C. K. SUNDARACHAR* (*University of Mysore, Bangalore*),J. F. STREIB (*Calif. Inst. of Technology, Pasadena*) ANDB. V. RAGHAVENDRA RAO (*University of Mysore, Bangalore*)

THE electrostatic generator of the moving belt type first developed by Van de Graaff¹ as a high voltage source and later successfully adapted for use with an accelerating tube by Tuve² at Washington and Herb³ at Wisconsin has proved to be a relatively inexpensive and compact apparatus for the production of high velocity protons or deuterons of 0.5 to 3 M.e.V. energy for nuclear disintegration experiments. The homogeneity in energy of the ions which it can yield to the extent of the fraction of a percent and the accurate control of voltage which it affords have made it particularly valuable in the study of proton-proton scattering⁴ which is of considerable theoretical interest and the study of resonance effects at energies corresponding to stationary states of the nuclear system. It is also well suited for the accurate measurement of the thresholds of nuclei for emission of neutrons under proton bombardment as well as of the angular distribution of disintegration products in regard to which the experimental data are meagre and the close study of which will reveal the nature of the interaction of angular momenta of the incident and bombarded particles.

The cyclotron extensively developed,⁵ at the University of California and of which there are nearly a dozen operating in different parts of the world at the present time can yield several hundred micro-amperes of positive ions of energies 5 to 15 M.e.V. While this feature makes the cyclotron especially suitable for breaking up heavy nuclei and for producing large quantities of radioactive isotopes of possible therapeutic value, the considerable expense involved in its construction and the variation in ion energy by as much as 10 per cent. offset these advantages. Condenser-rectifier voltage multiplying sets of the type⁶ developed by Cockcroft and Walton are used in some laboratories

and give a good yield of positive ion steady voltages. Commercial installations of this type of high voltage source yielding more than 1 M.V. are, however, very expensive. The cascade transformer which has been used effectively at the high voltage laboratory at Pasadena⁷ and at Ann Arbor, Michigan⁸ has proved useful for the study of neutron yields and in the study of gamma ray spectra where high intensities are necessary. It suffers from the main disadvantage of inhomogeneity of the ion beam. The steadiness of voltage and relative inexpensiveness combined with the fact that the parts can be easily built and assembled make the electrostatic generator with an accelerating tube unit ideally suited for use in physical laboratories with limited financial resources. The main features and the recent developments in its technique are set out in this article.

Essentially, the electrostatic generator consists of a spherical or cylindrical metal dome, one to two metres in diameter, supported on a textolite or flanged porcelain insulating support about 10 feet high, raised to a high positive potential by a rapidly moving belt, on which is sprayed electric charge by means of a comb system connected to a 10–20 K.V. transformer-rectifier set. The multiple section ion accelerating tube inside which the vacuum is maintained to less than 10^{-4} mm. of mercury by a set of big size oil diffusion pumps supported along the axis of the insulating tower. The hydrogen or deuterium gas charge tube used as the source of ions, the gas holder, the generator and transformer-rectifier units for the supply of filament current, anode and probe voltages are housed inside the dome. The gas flow potentials are adjusted by convenient hand arranged strings operating the controls.

Assuming a breakdown potential for air at ordinary pressure equal to 30 volts/cm., the maximum current conveyed by an 18-inch wide belt running at 3

* Visiting Professor at the California Institute of Technology, Pasadena, U.S.A., 1939–40.

ft./minute and arranged to carry both kinds of charge works out to be 450 micro-amperes. It is found, experimentally, that 75 per cent. of the theoretical current is delivered to the high potential electrode. The voltage is adjusted by the control of the spray voltage or by the use of a moveable "poker" consisting of a set of points placed close to the dome. If the belt system is enclosed in a steel tank filled with compressed air at about 100 lb. wt./sq. in., the available voltage is increased⁹ by a factor of 2 to 3. Fig. 1† gives a sketch of the

surfaces inside it and a set of adjustable negative point to plane gaps between adjacent rings produce corona current down the ring system and helps to regulate the voltage on the ion tube as well as the different electrodes (20 to 50 in number) constituting the electron lens system of the accelerating tube. Ample room is available inside the ring system for the insulating supports, belts and accelerating tube. Adverse stray currents arising from insulator leakage, corona from rough spots and discharges in the tube make it necessary to

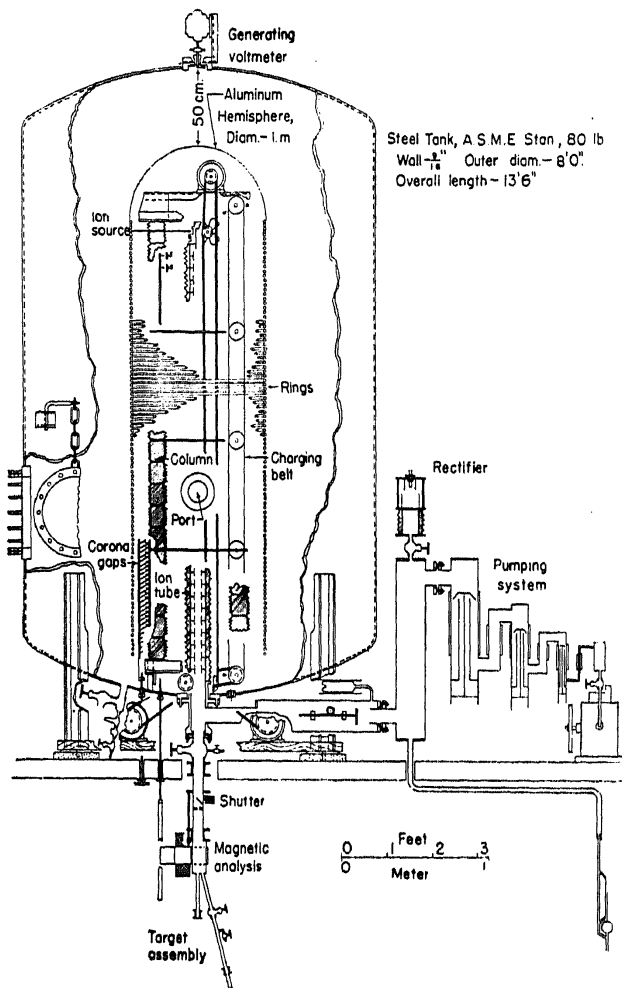

FIG. 1

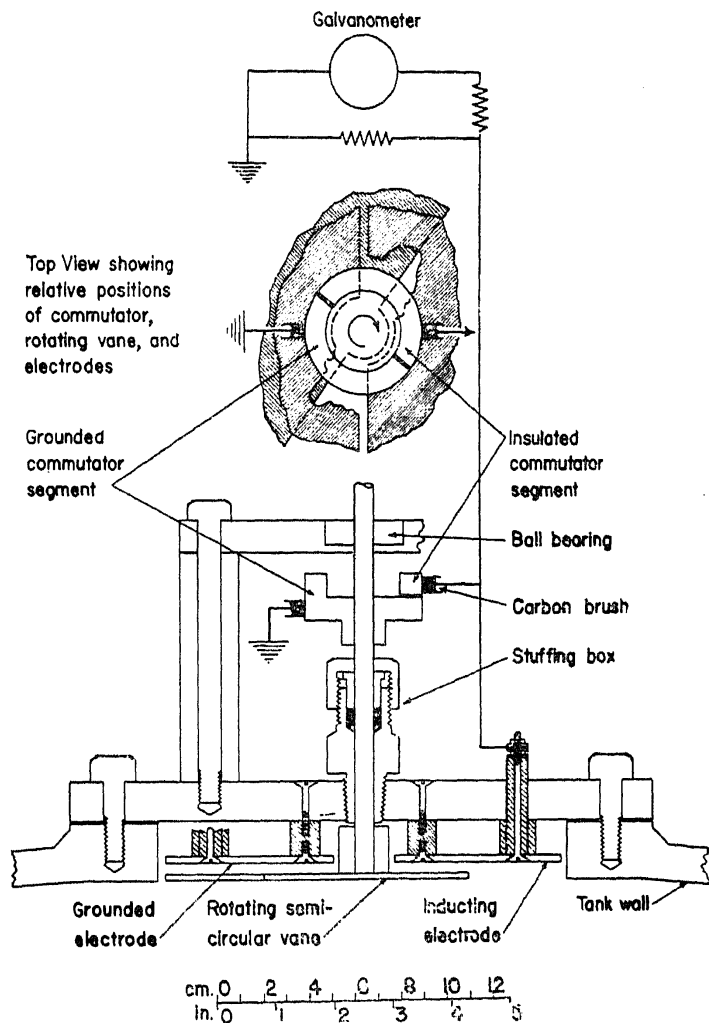

FIG. 2

pressure electrostatic generator (1-2 M.V.) built at the Kellogg laboratory of the California Institute of Technology, Pasadena and which has been extensively used for the study of fluorine-proton nuclear reactions. A series of metal rings surrounding the tower serve to define equipotential

have an adjustable corona current across the ring system. It is found¹⁰ that the maximum current which can be drawn from a point to plane corona before breakdown occurs is about 200 micro-amperes. The focussing of the ion beam is controlled chiefly by the potential adjustment of the first few electrodes of the electrostatic lens system. The theory of focussing has been worked out in considerable detail.¹¹ A focal spot of 3 to 4 mm. diameter with an ion

† We are indebted to Professors Lauritsen and Fowler of the California Institute of Technology for permission to reproduce Figs. 1 and 2.

current of 10 micro-amperes can be obtained with a well-designed ion source, which may be of the hot filament, low voltage or the capillary arc type. The ion beam is separated into its mass spectrum by an electromagnet.

Since concentric electrodes surrounding the charged dome give rise to a more uniform gradient and since high pressure air withstands higher gradients in shorter gaps the use of concentric electrodes increases the spark-over voltage. The available voltage in the latest type of pressure generator housed in a tank (20 ft. \times 5½ ft.) at Wisconsin¹² is found to increase from 2.6 to 3.5 M.V., using an arrangement of concentric electrodes.

The voltage is generally measured by means of a generating voltmeter.¹³ In one type, the alternating current generated by a spinning disc is measured by a sensitive galvanometer after rectification by a commutator. Fig. 2 gives a sketch of the arrangement used with the generator at Pasadena. Calibration is usually performed using the 440 K.V. peak of gamma ray resonance of the lithium-proton reaction. The sharpness of

the proton induced neutron emission reactions indicates that they also may be useful for calibration in high voltage work.¹⁴

- ¹ Van de Graaff, *Phys. Rev.*, 1931, **38**, 1919.
- ² Tuve, Hafstad and Dabl, *Phys. Rev.*, 1935, **48**, 315.
- ³ Herb, Parkinson and Kerst, *Phys. Rev.*, 1937, **51**, 75.
- ⁴ Heydenburg, Hafstad and Tuve, *Phys. Rev.*, 1939, **56**, 1078.
- ⁵ Kurie, *Journ. App. Phys.*, 1938, **9**, 691.
- ⁶ Cockcroft and Walton, *Proc. Roy. Soc. (A)*, 1932, **136**, 619.
- ⁷ Stephens and Lauritsen, *Rev. Sci. Inst.*, 1938, **9**, 51.
- ⁸ Crane, *Phys. Rev.*, 1937, **52**, 12.
- ⁹ Parkinson, Herb Bennet and McKibben, *Phys. Rev.*, 1938, **53**, 642.
- ¹⁰ T. Lauritsen, Ph.D. Thesis, C.I.T., 1939.
- ¹¹ Kirkpatrick and Beckerley, *Rev. Sci. Inst.*, 1936, **7**, 24. Klemperer and Wright, *Phys. Soc. Proc.*, 1939, **51**, 296.
- ¹² Herb, *et al.*, *Phys. Rev.*, 1940, **58**, 579.
- ¹³ Harnwell and Van Voorhis, *Rev. Sci. Inst.*, 1933, **4**, 540.
- ¹⁴ Haxby, Shoupp, Stephens and Wells, *Phys. Rev.*, 1940, **58**, 1035.

MANUFACTURE OF DRUGS FROM INDIGENOUS RESOURCES

“BORIC acid for the Medical Stores Department, hitherto obtained from England, may shortly be manufactured in India. It is proposed to purchase crude borax, imported from Tibet, and arrange for the manufacture of the boric acid. Another imported article, tablets Magnesii Sulphas 40 grains, is being manufactured by one of the Medical Stores Depots.

“Peptone powder, used as a culture medium, has hitherto been obtained from England. It is now manufactured in India.

A sample has been tested by the Military Laboratories and found to be a suitable substitute for the imported article. Accordingly the article has been transferred to the list of indigenous articles.” It may be added that Mr. B. N. Sastry and his colleagues working at the Indian Institute of Science, have perfected a process for the manufacture of peptone from fibrin by subjecting the material to the action of integrally pure papain.