

Anomalous VLF electric field perturbations associated with Chamoli earthquakes of March/April 1999

Raj Pal Singh, P. K. Mishra and Birbal Singh*

Department of Physics, R.B.S. College, Bichpuri, Agra 283 105, India

Employing borehole and terrestrial antennas, Very Low Frequency (VLF) electric field perturbations associated with Chamoli earthquakes which occurred in the months of March and April 1999 have been monitored at our Agra station (geographic lat. 27.8°N, long. 78°E). The results show that electric field perturbations started appearing in the form of noise bursts 16 days prior to the occurrence of the main shock on 29 March 1999. In majority of the cases of the noise bursts the effect was observed by borehole antenna only, indicating that the signal propagated through crustal region. This result is interpreted in terms of propagation of signals through conductive channels along Delhi–Haridwar ridge and parallel to them between the source and the observing station.

THE generation of electromagnetic emissions in wide frequency range from Ultra Low Frequency (ULF) to High Frequency (HF) band ranging from 0.01 to 1 MHz and their precursory characteristics have been reported by many workers in the recent past¹⁻⁴. Such emissions have also been observed in the ionosphere and magnetosphere by satellite-borne receivers⁵⁻⁷. The generation of electromagnetic emissions during earthquakes has been verified in laboratory experiments involving fracturing of quartz-bearing rocks⁸⁻¹¹. It has been suggested that sudden electric field changes during piezo-electrification of the rocks under compression, redistribution of charges in the crust or in the earth's atmospheric system and charge particle emissions from the fractured surfaces are largely responsible for electromagnetic-emissions during earthquakes⁸⁻¹².

Among various ground-based techniques employed for monitoring the precursory electromagnetic emissions associated with earthquakes, the sub-surface measurements of electric and magnetic field emissions at frequencies between ULF (0.01 Hz–10 Hz) and VLF (3 kHz–30 kHz) have attracted greater attention recently¹³⁻¹⁷. Employing this technique, an interesting result was obtained by Fujinawa and Takahashi¹⁸ in which they found increased number of VLF pulses prior to the occurrence of Kurile earthquake in 1994. Very convincing ULF precursors to recent Taiwan earthquakes of 21 September 1999 had been found one week before by Japanese workers¹⁹. Several other workers have also attempted the study of earthquake prediction based on monitoring of the sub-surface

electric and magnetic field changes (see Hayakawa and Fujinawa²⁰ and Hayakawa²¹ and references therein).

Recently, we have also started sub-surface measurements of VLF vertical electric field components employing a borehole antenna. We have observed precursory characteristics of such emissions associated with some distant severe earthquakes that occurred in Afghanistan in the north-west and in some parts of China in the north-east. We have interpreted this result in terms of propagation of the emissions through Main Boundary Fault (MBF) and transverse conductive channels near Delhi and Agra, which might act like a waveguide between the source and the observing station²²⁻²⁴.

In the present paper, we analyse the data corresponding to severe and prolonged earthquakes that occurred in the months of March and April 1999 in Chamoli region of UP hills in north India. Our results show that electromagnetic activity started about 16 days prior to the occurrence of the main shock on 29 March 1999 in the region and continued till the shocks subsided in April 1999.

The experimental set-up shown in Figure 1 is similar to those we have used earlier²²⁻²⁴, except for some modifications. Here, we describe the arrangement briefly. We have used two types of antennas: a borehole antenna and a terrestrial antenna. The borehole antenna is 120 m in length and 4 mm diameter placed in a watertight PVC pipe of 3.75 cm diameter with its lower end tightly fitted with an insulating black cork at the bottom. This is placed in another PVC pipe of 7.5 cm diameter which is open at both ends and is used to reduce the upward thrust (buoyancy) of underground water on the pipe containing the antenna. This antenna is connected to transistorized pre-amplifier and main-amplifiers of gains 40 dB each and the amplified signal is passed through active band pass filter (peak frequency 3 kHz, BW 250 Hz), peak detector and finally to DC ink chart recorder model A 602 C, Esterline Angus, USA. The other channel of this recorder is used to record the amplified signal through a similar arrangement from a terrestrial antenna of 20 m height, installed near the observation site by the side of the 30-feet high building in our department. Employing these two antennas, we

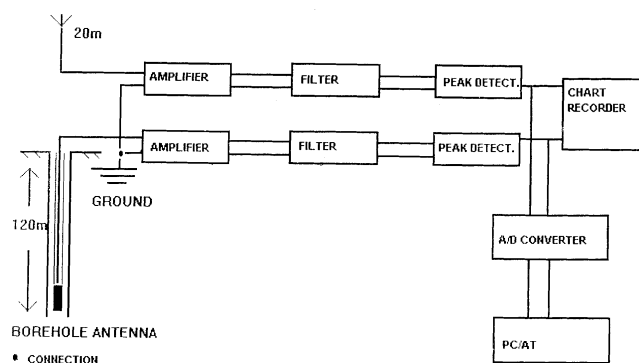

Figure 1. Experimental set-up to monitor vertical electric fields associated with seismic activities using borehole and terrestrial antennas.

*For correspondence. (e-mail: birbal@sancharnet.in)

are able to monitor the electric field variations both underground and in the atmosphere simultaneously. Observations were taken round-the-clock, except for a couple of breaks, two hours in the morning between 0700 and 0900 h and two hours in the evening between 1700 and 1900 h at Bichpuri, a rural area, about 12 km west of Agra where electric and electromagnetic noises are very low.

The earthquake data for the year 1998–1999 were obtained from India Meteorological Department (IMD), New Delhi and United States Geological Survey. Since in this paper our main aim is to discuss the earthquakes that occurred in Chamoli hills of north India (geographic lat. 30.51°N, long. 79.4°E), we present in Table 1 a list of earthquakes that occurred between 25 February and 14 May 1999 in Chamoli only. However, description of major earthquakes that occurred elsewhere and in different months of the year, which will be relevant to the discussions on Chamoli earthquakes will be given later in the article. In Chamoli region, earthquakes occurred only in the months shown in Table 1 and no report of earthquake activity was available during other months of the year.

The main devastating shock occurred in Chamoli region on 29 March 1999 around 0035 h IST (Indian Standard Time), which was followed by seven shocks on the same day. The earthquake activity continued for a prolonged period of time till 14 May 1999, almost at the same place within ± 50 km from the epicentre of the main shock. As shown in Table 1, the focal depth of the earthquakes that occurred on 25 February 1999 and 14 May 1999 was unknown (33 km), whereas all other earthquakes occurred almost at the same depth of 10 km. The main shock on 29 March, however, occurred at the focal depth of 15 km. This indicates a seismic swarm activity, the source of which may possibly lie in magma intrusion where a kind

of stick-slip motion was induced by a step-like change of tectonic forces²⁵.

In our earlier papers^{23,24} we have shown the waveforms of various types of noise bursts recorded in this experiment using borehole antenna, some of which originated from different known electromagnetic sources like spherics (VLF electromagnetic waves generated from long distance lightning discharges), local lightning activities, mid-latitude VLF emissions (electromagnetic emissions from the sources in the ionosphere) and local radio stations. The origin of other waveforms which showed typical characteristics like slow non-spike type variations with moderately enhanced amplitude was not known, but in majority of the cases, such waveforms occurred either prior to or after the occurrence of some major earthquakes in India or around. One typical waveform of this kind recorded by our borehole antenna will be shown later in the article.

In order to study the noise-burst activity associated with Chamoli earthquakes, we counted all kinds of noise bursts per day excluding those produced by mid-latitude emissions which are of very long durations (5–6 h) and are very well identified. The occurrence of noise-burst activity per day is studied from December 1998 to June 1999, three months before to three months after the occurrence of severe earthquakes in Chamoli. In Figure 2 *a* we show by solid lines the number of noise bursts recorded by our system (mostly by borehole antenna) on each day between December 1998 and February 1999. By the term noise burst we mean rapid variations in the amplitude of the signal in patches of short durations of about a few minutes to 2–3 h (refs 22–25). The dotted lines in Figure 2 *a* indicate the average data of the noise-burst activity for six months between January and June 1999 which is repeated in each panel. By showing the average data in all these panels our main purpose is to eliminate the regularly appearing noise bursts caused by known electromagnetic sources like radio transmissions, spherics, other local noises, etc. and pay specific attention to those in which per day occurrences are much above the average. Such enhanced occurrences may possibly result from some unusual events. The downward arrows in Figure 2 *a* indicate the days on which the major earthquakes ($M_s \geq 4$) occurred in the respective months in India or around, within the latitude range 20°–40°N and longitude range 70°–100°E and close to the MBF. The numbers above the arrows indicate the magnitudes of the earthquakes. The magnitudes which are marked by stars correspond to earthquakes that occurred in Afghanistan in a region which is connected with MBF (to be discussed later). The crosses along the solid lines between 6 and 7 February, 13–14 February and 18–26 February 1999 indicate the non-availability of data due to system failure. Figure 2 *b* is similar to Figure 2 *a* except that here we show the data for four months between March and June 1999 which correspond mostly to Chamoli region, details of which are

Table 1. List of earthquakes that occurred in Chamoli hills of north India between February and May 1999

Date	Time, IST (h)	Geographic		Magnitude	Depth (km)
		Lat. (°)	Long. (°)		
25.2.99	1643	30.66	78.88	4.0	33
29.3.99	0035	30.51	79.40	6.6	15
29.3.99	0106	30.32	79.34	5.0	10
29.3.99	0117	30.34	79.31	4.7	10
29.3.99	0434	30.36	79.48	4.4	10
29.3.99	0450	30.34	79.49	4.5	10
29.3.99	1419	30.21	79.25	4.6	10
29.3.99	1850	30.29	79.29	4.6	10
30.3.99	2121	30.19	79.31	4.5	10
31.3.99	0232	30.38	79.33	5.3	10
01.4.99	0818	30.53	79.41	4.5	10
07.4.99	0107	30.41	79.32	5.1	10
07.4.99	0216	30.33	79.34	4.6	10
07.4.99	2119	30.25	79.32	4.9	10
07.4.99	2153	30.26	79.29	4.7	10
14.4.99	2254	30.26	79.31	4.9	10
18.4.99	2246	30.24	79.30	4.9	10
07.5.99	2242	30.11	79.35	4.5	10
14.5.99	1401	30.32	79.32	4.6	33

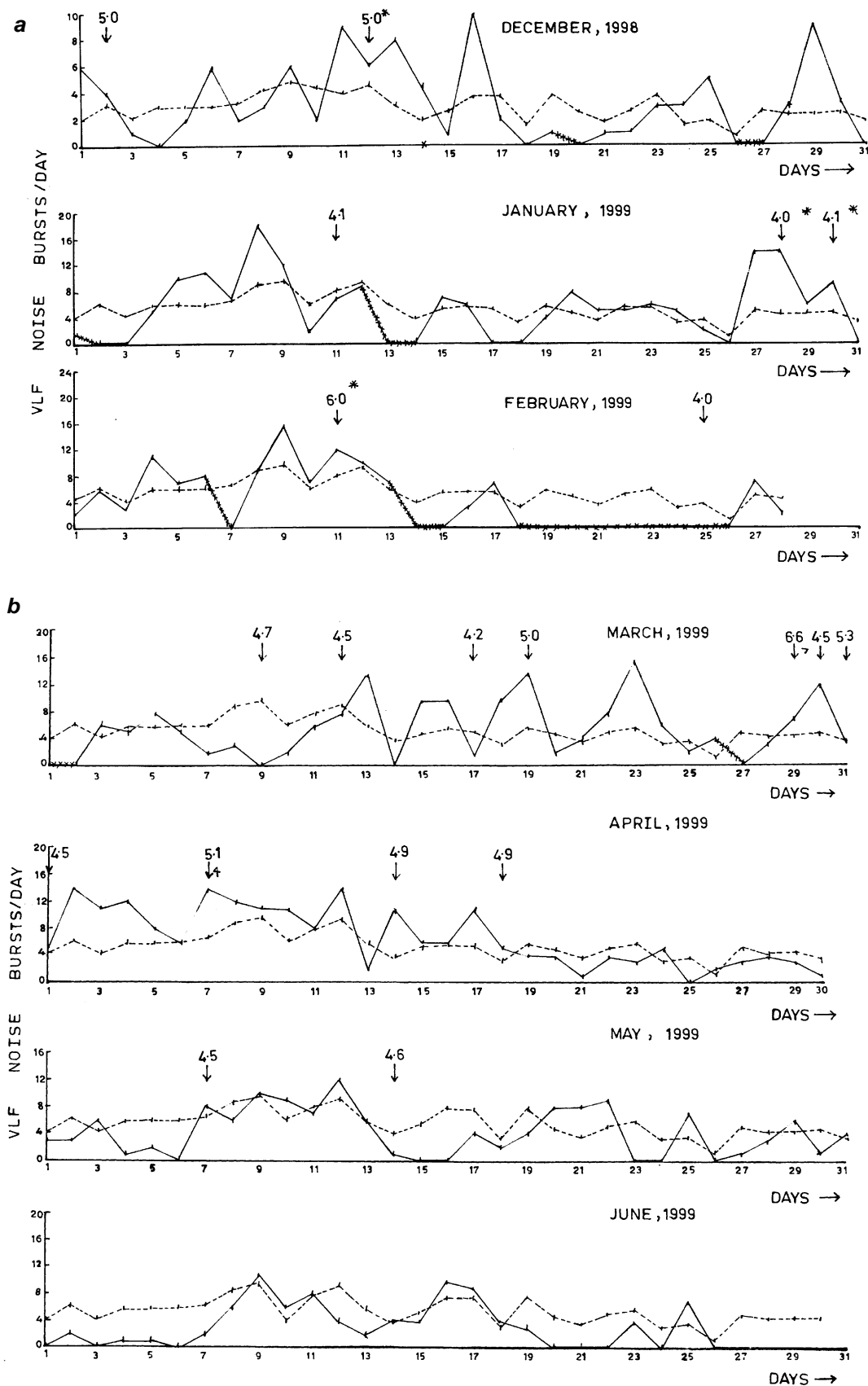

Figure 2. *a*, Daily variations of VLF noise bursts during December 1998–February 1999 (solid lines). Dotted lines in these panels represent the averages for six months (January to June 1999) of the daily noise bursts. For other details see the text. *b*, Same as Figure 2 *a*, except that the daily variations are for the months March to June 1999.

given in Table 1. The most severe earthquake in the region occurred on 29 March with a magnitude of 6.6 on the Richter scale. Number 7 (written near the tip of the arrow on 29 March) and number 4 (written near the tip of arrow on April 7) indicate the number of additional shocks that occurred on these days. The earthquakes between March 9 and 19 are given in Table 2. In fact, these earthquakes occurred in other parts of India and their focal depths were either very deep (> 100 km) or unknown (33 km).

From a detailed study of Figure 2 *a* and *b*, we find two types of enhanced noise-burst activities; one type in which the activities are isolated and correlated positively with isolated earthquakes, and another type in which the activities are prolonged and correspond to prolonged seismic activities (earthquake swarm). Examples of the first type are seen in Figure 2 *a* between 5 and 17 December 1998, 5–9 January, 26–31 January and 9–11 February 1999. In contrast to these, there is a prolonged activity between 13 March and 18 April in Figure 2 *b* which corresponds to seismic swarm activity in Chamoli region. The occurrences of the first type of enhanced noise bursts prior to and after major earthquakes that occurred in different months of 1998 have already been discussed by Singh *et al.*²³. In fact, these are the common features and have been observed both in cases of distant and local earthquakes. In many other cases, there are enhanced noise bursts which are not directly correlated with earthquakes. Examples of these are shown on 6, 9 and 16 December. However, these may be considered as pre- and post-seismic effects of the earthquake of 12 December. The enhanced noise burst on 29 December is not correlated with earthquakes and Singh and Singh²⁴ have shown that this was produced by non-seismic sources. Such known seismic sources may be intensified spherics or local lightning activities. This type of noise is rarely observed because the high attenuation in crustal region reduces the contamination of radio noises from external sources unless they are very strong.

Now we discuss the prolonged noise-burst activity corresponding to seismic swarm between 29 March and 18 April in Chamoli region shown in Figure 2 *b*. An interesting result is that the enhanced noise-burst activity began 16 days prior to the occurrence of main shock on

29 March and continued till 18 April. After that, since there was no earthquake during that month, the activity subsided. Here, one may question our interpretation that the enhanced noise-burst activities prior to the main shock between 13 and 23 March were due to the earthquakes in Chamoli and not due to those shown on 9, 12, 17 and 19 March, which occurred somewhere else in India (refer Table 2). We may mention here that the effect of these earthquakes may not be so significant because of the fact that (i) these earthquakes were moderate; (ii) focal depths of these earthquakes were either very deep (> 100 km) or unknown (33 km); and (iii) similar earthquakes occurring on 8 and 9 March did not produce any enhancement in the noise burst. This is supported also by the fact that the isolated earthquakes of 7 and 14 May which occurred in Chamoli region itself did not produce any significant enhancement in noise-burst activity. Hence, the enhanced noise-burst activity between 13 and 23 March may be considered as an effect of intense earthquake activity on 29 March and after in the Chamoli region.

Figure 3 shows the waveform of a typical noise burst recorded at our station on 28 March 1999, between 0345 and 0545 h IST, about 22 h before the occurrence of the main shock. This type of noise burst is most commonly observed during the period of seismic activities. An interesting characteristic of this noise burst is that it was recorded by the borehole antenna only. This is evident by looking at the other panel which shows no variation in electric field recorded by the terrestrial antenna. This shows that the signal propagated through the crustal region and no leakage took place to the atmosphere.

Figure 4 shows the histogram of enhanced noise-burst activity observed during each month between December 1998 and June 1999. In plotting these histograms, only those days are considered on which the number of noise bursts were larger (≥ 2) than the average noise bursts. Figure 4 shows falling noise-burst activity from December to February and then sudden enhancement in March,

Table 2. List of earthquakes that occurred in other parts of India in March prior to Chamoli earthquakes

Date	Time, IST (h)	Geographic		Magnitude	Depth (km)
		Lat., deg	Long., deg		
11.1.99	1843	35.41	77.48	4.1	33
08.3.99	1636	35.69	88.54	3.9	33
09.3.99	1539	35.72	88.60	4.7	33
12.3.99	0342	25.64	94.32	4.5	105
17.3.99	0357	28.52	78.23	4.2	33
19.3.99	1124	27.00	85.50	5.0	33
22.3.99	1526	29.00	76.70	3.5	10

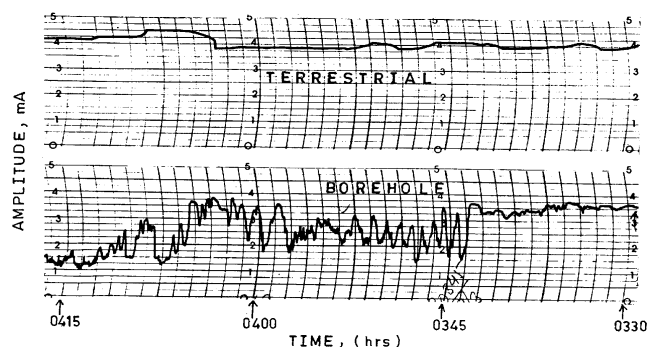

Figure 3. Typical waveform of the noise burst recorded by borehole antenna 22 h before the devastating earthquake of 29 March 1999 in Chamoli area. No signal perturbation was recorded by terrestrial antenna during this period. This type of noise burst is usually observed during seismic events.

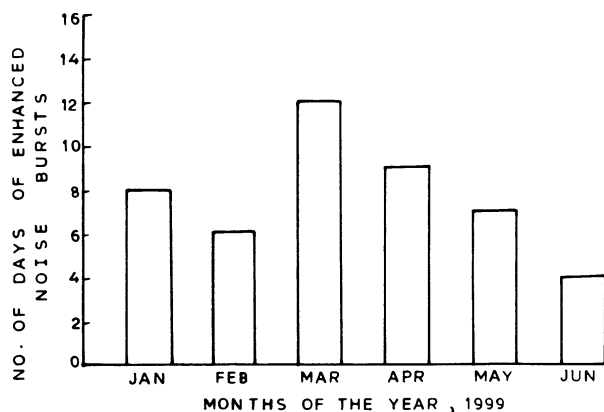

Figure 4. Histogram of number of days of enhanced noise burst during December 1998 to June 1999.

followed by gradual fall during the rest of the months. Falling noise-burst activity from December onward is a normal characteristic of spheric activities, which is due to decreasing distant lightning activities. However, the sudden enhancement in March is quite unusual and may be attributed to enhanced noise burst caused by Chamoli earthquakes.

How did the electric field perturbations generated in the Chamoli region reach the Agra station? In order to answer this, we may mention here that there were great possibilities of propagation of such signals through seismic faults and electrically conductive channels as discussed in our earlier papers²²⁻²⁴ and by many other workers elsewhere^{2,26,27}. In general, it has been reported that a mechanical distortion of the order of 10^{-8} may affect the conductivity variation such that it may be magnified by $10^3 \sim 10^4$ times the distortion owing to conductivity characteristic of rock and so the signal may be received several hundred to, in some cases, thousands of kilometers away from the epicentre²⁸. Here, we may emphasize that the signal generated from Chamoli region reached the Agra station through conductive channels along Delhi-Haridwar Ridge (DHR) and parallel to them, near Agra. The electrical conductivity characteristics of such channels has already been studied by Indian workers^{29,30}. Figure 5 shows the locations of Chamoli earthquakes, DHR and transverse conductive channel. The solid line indicates the MBF on which four major earthquakes of magnitude greater than 8 have occurred in the last 100 years. The locations of these earthquakes are shown by big stars and the years of their occurrence are also indicated.

Our result that VLF electromagnetic noise-burst activity started 16 days prior to the occurrence of the devastating earthquake in Chamoli is not uncommon and there are several evidences of long days precursors observed by other workers also. For example, Fujinawa and Takahashi¹⁴ have reported precursory times ranging from 0.4 h to 7.8 days from observations at several stations in Japan.

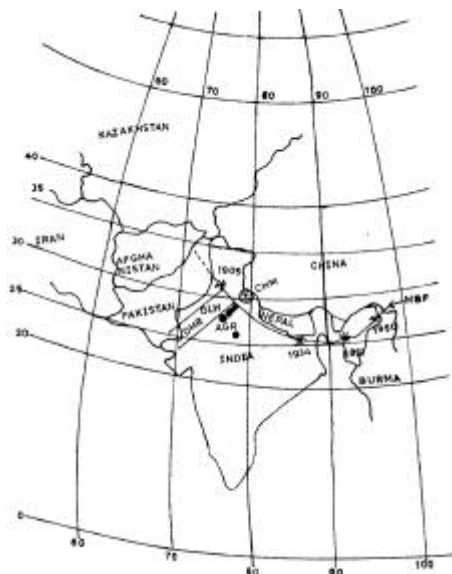

Figure 5. Map showing the location of Chamoli region (encircled), Delhi-Haridwar Ridge (DHR, two parallel lines), Main Boundary Fault (MBF, thick solid line) and observing station Agra (AGR, solid circle).

Enomoto and Hashimoto³¹ have also reported precursory times between 7 h and 4 days. However, in these cases earthquakes were moderate and isolated and in case of severe and prolonged seismic activities such as that in Chamoli, the electromagnetic signals may be observed much earlier. For example, Matsumoto *et al.*³² reported anomalous electric field changes about two months before the seismic swarm of east coast of Izu peninsula.

- Gokhberg, M. B., Morgunov, V. A., Yoshino, T. and Tomizawa, I., *J. Geophys. Res.*, 1982, **87**, 7824-7828.
- Warwick, J., Stocker, C. and Meyer, T. R., *J. Geophys. Res.*, 1982, **87**, 2851-2859.
- Parrot, M., Lefuvre, Y. and Godfroy, P., *Ann. Geophys.*, 1985, **3**, 731.
- Fraser-Smith, A. C., Barnardi, A., McGill, P. R., Ladd, M. E., Helliwell, R. A. and Villard, O. G. Jr., *Geophys. Res. Lett.*, 1990, **17**, 1465-1468.
- Parrot, M. and Mogilvesky, M. M., *Phys. Earth Planet. Int.*, 1989, **57**, 86-99.
- Larkina, V. I., Migulin, V. V., Molchanov, O. A., Kharkove, I. P., Inchin, A. S. and Scheriteova, N., *Phys. Earth Planet. Inter.*, 1989, **57**, 100-109.
- Molchanov, O. A., Mazhaeva, O. A., Goliavin, A. N. and Hayakawa, M., *Ann. Geophys.*, 1993, **11**, 431-440.
- Nitsan, U., *Geophys. Res. Lett.*, 1977, **4**, 333-337.
- Ogawa, T., Oike, K. and Miura, T., *J. Geophys. Res.*, 1985, **90**, 6245-6249.
- Yamada, I., Masuda, K. and Mizutni, H., *Phys. Earth Planet. Inter.*, 1989, **57**, 157-168.
- Enomoto, H. and Hashimoto, H., in *Electromagnetic Phenomena Related to Earthquake Prediction* (eds Hayakawa, M. and Fujinawa, Y.), Terra Sci. Pub Co, Tokyo, 1994, pp. 261-269.
- Parrot, M., in *Electromagnetic Phenomena Related to Earthquake Prediction* (eds Hayakawa, M. and Fujinawa, Y.), Terra Sci. Pub Co, Tokyo, 1994, pp. 361-372.
- Fujinawa, Y. and Takahashi, K., *Nature*, 1990, **347**, 376-378.
- Fujinawa, Y. and Takahashi, K., in *Electromagnetic Phenomena*

- Related to *Earthquake Prediction* (eds Hayakawa, M. and Fujinawa, Y.), Terra Sci. Pub Co, Tokyo, 1994, pp. 131–148.
15. Yoshino, T., *J. Sci. Explor.*, 1991, **5**, 121–144.
 16. Hata, M. and Yabashi, S., in *Electromagnetic Phenomena Related to Earthquake Prediction* (eds Hayakawa, M. and Fujinawa, Y.), Terra Sci. Pub Co, Tokyo, 1994, pp. 159–174.
 17. Quin, S., Yian, J., Cao, H., Shi, S., Lu, Z., Li, J. and Ren, K., in *Electromagnetic Phenomena Related to Earthquake Prediction* (eds Hayakawa, M. and Fujinawa, Y.), Terra Sci. Pub Co, Tokyo, 1994, pp. 205–211.
 18. Fujinawa, Y. and Takahashi, K., Paper presented at IUGG Meeting Boulder, Colorado, 2–4 July 1995.
 19. Ohta, K., Paper presented at the International Workshop on Seismo-Electromagnetic and Space Science held at Agra during 19–21 December 2000.
 20. Hayakawa, M. and Fujinawa, Y., *Electromagnetic Phenomena Related to Earthquake Prediction*, Terra Sci. Pub Co, Tokyo, 1994.
 21. Hayakawa, M., *Atmospheric and Ionospheric Electromagnetic Phenomenon Associated with Earthquakes*, Terra Sci. Pub Co, Tokyo, 1999.
 22. Singh, B., Singh, R. P., Bansal, V., Kumar, M. and Hayakawa, M., *J. Atmos. Electr.*, 1999, **19**, 119–134.
 23. Singh, R. P., Singh, B., Bansal, V. and Hayakawa, M., *J. Atmos. Electr.*, 2000, **20**, 7–20.
 24. Singh, R. P. and Singh, B., *Curr. Sci.*, 2000, **78**, 492–498.
 25. Okada, Y. and Yamamoto, E., *J. Phys. Earth*, 1991, **39**, 177–195.
 26. Oike, K. and Ogawa, T., *J. Geomagn. Geoelectr.*, 1986, **38**, 1031–1040.
 27. Yoshino, T. and Tomizawa, I., *Res. Lett. Atmos. Electr.*, 1992, **12**, 203–210.
 28. Rikitake, T. and Yamazaki, Y., *Proc. Jpn. Acad.*, 1967, **44**, 447–482.
 29. Arora, B. R. and Reddy, C. D., in *Uttarkashi Earthquake* (eds Gupta, H. K. and Gupta, G. D.), Geol. Soc. India, 1995, Memoir No. 30, pp. 109–124.
 30. Kayal, J. R., Ghosh, B., Chakraborty, P. and De, R., in *Uttarkashi Earthquake* (eds Gupta, H. K. and Gupta, G. D.), Geol. Soc. India, 1995, Memoir No. 30, pp. 25–41.
 31. Enomoto, Y. and Hashimoto, H., in *Electromagnetic Phenomena Related to Earthquake Prediction* (eds Hayakawa, M. and Fujinawa, Y.), Terra Sci. Pub Co, Tokyo, 1994, pp. 261–270.
 32. Matsumoto, Y., Fujinawa, Y. and Takahashi, K., *J. Atmos. Electr.*, 1996, **16**, 175–191.

ACKNOWLEDGEMENTS. We thank the department of Science and Technology, Government of India, New Delhi for financial support in the form of a major research project. We also thank the Director General, Indian Meteorological Department, New Delhi for supplying earthquake data.

Received 4 August 2000; revised accepted 14 February 2001

Inheritance of resistance to brown planthopper in an *Oryza rufipogon* (Griff.)-derived line in rice

Li Rongbai[†], Qin Xueyi[†], Wei Sumei[†],
M. P. Pandey^{*‡}, P. K. Pathak^{*}, Huang Fenguan[†],
Li Qing[†] and Luo Shanyu[†]

[†]Guangxi Academy of Agricultural Sciences, Nanning 530007, China

^{*}Department of Genetics and Plant Breeding, G.B. Pant University of Agriculture and Technology, Pantnagar 263 145, India

Screening of 94-42-5-1, a derivative of wild *Oryza rufipogon* (Griff.) accession revealed its high resistance against three brown planthopper (BPH) biotypes from the predominantly rice-growing regions of Asia, viz. biotype 2, Cuulong (Vietnam) and Pantnagar (India), the latter two being the most virulent. Inheritance studies indicated the nature of its resistance to be monogenic recessive against the Pantnagar biotype and digenic recessive against Cuulong biotype. One of the two recessive resistance genes was allelic to *bph4*, while the other was non-allelic with all other known BPH resistance genes of cultivated species *O. sativa* L. The new source with the AA genome identical to the cultivated rice, would have great potential in combating the problem for BPH resistance in cultivated rice.

BROWN planthopper (BPH) is considered as the most serious pest throughout the rice-growing areas of the world. Variations in BPH biotypes are known to occur. Of

these, Cuulong (southern Vietnam) and Pantnagar (northern India) biotypes are highly virulent as none of the nine resistance genes reported^{1–5} in the cultivated species, *Oryza sativa* L., confer high degree of resistance against these biotypes^{6,7}. The biotype 2 is predominant in most rice-growing areas of China⁷. Since the resistance gene(s) from the related wild species with AA genome are easy to transfer into elite cultivars, a study was undertaken to search for new gene(s) for resistance in the wild species, *Oryza rufipogon* Griff.

The materials comprised 94-42-5-1 and 11 tester varieties. The former is a doubled haploid homozygous BPH resistance line derived from anther culture of a wild *O. rufipogon* accession 94-42, highly resistant to BPH⁸. The materials were screened against biotype 2 and Cuulong biotype in China at Guangxi Academy of Agricultural Sciences, Nanning and Pantnagar biotype in India at G.B. Pant University of Agriculture and Technology, Pantnagar. The three biotypes – biotype 2, Cuulong and Pantnagar, collected from Nanning, Omon and Pantnagar, represented the most virulent biotypes in southern China, southern Vietnam and northern India, respectively. For genetic analysis of resistance, F₁, F₂, BC₁P₁ and BC₁P₂ progenies from the cross of 94-42-5-1 with susceptible variety, TN 1 were screened with BPH population of Pantnagar and Cuulong biotypes. The F₃ progenies of the cross were screened against Pantnagar biotype only. The allelic relationship of resistance genes of 94-42-5-1 was also investigated. For this purpose, 94-42-5-1 was crossed with five testers having known recessive genes, viz. *bph2*, *bph4*, *bph5*, *bph7* and *bph8* (Table 1). The parental, F₁

[‡]For correspondence. (e-mail: mppandey@lycos.com)